

Fracture behaviour of rubber used for sealing application at fatigue loading conditions.

Bc. Aleš Machů

Master's thesis
2018



Tomas Bata University in Zlín
Faculty of Technology

Univerzita Tomáše Bati ve Zlíně

Fakulta technologická

Ústav inženýrství polymerů

akademický rok: 2017/2018

ZADÁNÍ DIPLOMOVÉ PRÁCE

(PROJEKTU, UMĚLECKÉHO DÍLA, UMĚLECKÉHO VÝKONU)

Jméno a příjmení: **Bc. Aleš Machů**
Osobní číslo: **T16196**
Studijní program: **N2808 Chemie a technologie materiálů**
Studijní obor: **Inženýrství polymerů**
Forma studia: **prezenční**

Téma práce: **Lomové chování pryže pro těsnící aplikace při cyklickém dynamickém zatěžování.**

Zásady pro vypracování:

1. Rešerše na téma lomové chování pryže na bázi EPDM.
2. Stanovení aplikačních okrajových podmínek pro cyklické dynamické zatěžování pryžových těsnění dle vhodného příkladu z praxe.
3. Návrh receptur vhodných pro aplikaci do těsnících aplikací na bázi EPDM kaučuku, 4 receptury, při variaci obsahu sazí a typu kaučuku.
4. Výroba gumárenských směsí na bázi navržených receptur
5. Provedení základní charakterizace popisu mechanických vlastností těchto materiálů.
6. Experimentální stanovení hodnoty minimální energie potřebné pro růst trhliny.
7. Provedení experimentálních únavových analýz při cyklickém dynamickém zatěžování při variaci okrajových podmínek zatěžování.
8. Stanovení hodnot trhacích energií v závislosti na rychlosti růstu trhliny.
9. Písemné vypracování diplomové práce v anglickém jazyce.

Rozsah diplomové práce:

Rozsah příloh:

Forma zpracování diplomové práce: **tištěná/elektronická**

Seznam odborné literatury:

- [1] MALÁČ, J. Gumárenská technologie I. Zlín: Univerzita Tomáše Bati ve Zlíně, 2005.
[2] Kadlčák, J. FILLER DISPERSION AND RHEOLOGY OF POLYMERS, Zlín, 2014, Doctoral Thesis, Tomas Bata University in Ziln, Faculty of Technology, Supervisor Čermák R.
[3] GENT, Alan N. Engineering with rubber: how to design rubber components. 3rd ed. Cincinnati: Hanser Publishers, c2012. ISBN 1569905088.
[4] T. Alshuth, F. Abraham, and S. Jerrams (2002) Parameter Dependence and Prediction of Fatigue Properties of Elastomer Products. Rubber Chemistry and Technology: September 2002, Vol. 75, No. 4, pp. 635–642.
[5] Alshuth, T., Abraham, F., & Jerrams, S. (2002). Parameter Dependence and Prediction of Fatigue Properties of Elastomer Products. Rubber Chemistry and Technology, 75(4), 635–642. doi:10.5254/1.3544990
[6] Stoček, R., Heinrich, G., Gehde, M., & Kipscholl, R. (2013). Analysis of Dynamic Crac
[7] Hamza, S.s. "Effect of aging and carbon black on the mechanical properties of EPDM rubber." Polymer Testing 17, no. 2 (1998): 131–37. doi:10.1016/s0142-9418(97)00039-1.

Vedoucí diplomové práce:

Ing. Radek Stoček, Dr.

Ústav inženýrství polymerů

Datum zadání diplomové práce:

2. ledna 2018

Termín odevzdání diplomové práce:

16. května 2018

Ve Zlíně dne 1. března 2018



doc. Ing. František Buňka, Ph.D.

děkan

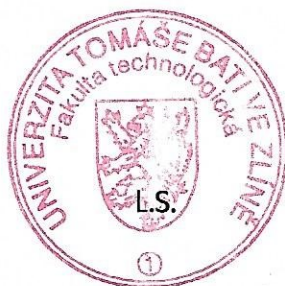

doc. Ing. Tomáš Sedláček, Ph.D.

ředitel ústavu

Příjmení a jméno: Maehů Ales

Obor: IP

PROHLÁŠENÍ

Prohlašuji, že

- beru na vědomí, že odevzdáním diplomové/bakalářské práce souhlasím se zveřejněním své práce podle zákona č. 111/1998 Sb. o vysokých školách a o změně a doplnění dalších zákonů (zákon o vysokých školách), ve znění pozdějších právních předpisů, bez ohledu na výsledek obhajoby ¹⁾;
- beru na vědomí, že diplomová/bakalářská práce bude uložena v elektronické podobě v univerzitním informačním systému dostupná k nahlédnutí, že jeden výtisk diplomové/bakalářské práce bude uložen na příslušném ústavu Fakulty technologické UTB ve Zlíně a jeden výtisk bude uložen u vedoucího práce;
- byl/a jsem seznámen/a s tím, že na moji diplomovou/bakalářskou práci se plně vztahuje zákon č. 121/2000 Sb. o právu autorském, o právech souvisejících s právem autorským a o změně některých zákonů (autorský zákon) ve znění pozdějších právních předpisů, zejm. § 35 odst. 3 ²⁾;
- beru na vědomí, že podle § 60 ³⁾ odst. 1 autorského zákona má UTB ve Zlíně právo na uzavření licenční smlouvy o užití školního díla v rozsahu § 12 odst. 4 autorského zákona;
- beru na vědomí, že podle § 60 ³⁾ odst. 2 a 3 mohu užít své dílo – diplomovou/bakalářskou práci nebo poskytnout licenci k jejímu využití jen s předchozím písemným souhlasem Univerzity Tomáše Bati ve Zlíně, která je oprávněna v takovém případě ode mne požadovat přiměřený příspěvek na úhradu nákladů, které byly Univerzitou Tomáše Bati ve Zlíně na vytvoření díla vynaloženy (až do jejich skutečné výše);
- beru na vědomí, že pokud bylo k vypracování diplomové/bakalářské práce využito softwaru poskytnutého Univerzitou Tomáše Bati ve Zlíně nebo jinými subjekty pouze ke studijním a výzkumným účelům (tedy pouze k nekomerčnímu využití), nelze výsledky diplomové/bakalářské práce využít ke komerčním účelům;
- beru na vědomí, že pokud je výstupem diplomové/bakalářské práce jakýkoliv softwarový produkt, považují se za součást práce rovněž i zdrojové kódy, popř. soubory, ze kterých se projekt skládá. Neodevzdání této součásti může být důvodem k neobhájení práce.

Ve Zlíně 15.5.2018



¹⁾ zákon č. 111/1998 Sb. o vysokých školách a o změně a doplnění dalších zákonů (zákon o vysokých školách), ve znění pozdějších právních předpisů, § 47 Zveřejňování závěrečných prací:

(1) Vysoká škola nevdělečně zveřejňuje disertační, diplomové, bakalářské a rigorózní práce, u kterých proběhla obhajoba, včetně posudků oponentů a výsledku obhajoby prostřednictvím databáze kvalifikačních prací, kterou spravuje. Způsob zveřejnění stanoví vnitřní předpis vysoké školy.

(2) *Disertační, diplomové, bakalářské a rigorózní práce odevzdané uchazečem k obhajobě musí být též nejméně pět pracovních dnů před konáním obhajoby zveřejněny k nahlížení veřejnosti v místě určeném vnitřním předpisem vysoké školy nebo není-li tak určeno, v místě pracoviště vysoké školy, kde se má konat obhajoba práce. Každý si může ze zveřejněné práce pořizovat na své náklady výpisy, opisy nebo rozmnoženiny.*

(3) *Platí, že odevzdáním práce autor souhlasí se zveřejněním své práce podle tohoto zákona, bez ohledu na výsledek obhajoby.*

²⁾ *zákon č. 121/2000 Sb. o právu autorském, o právech souvisejících s právem autorským a o změně některých zákonů (autorský zákon) ve znění pozdějších právních předpisů, § 35 odst. 3:*

(3) *Do práva autorského také nezasahuje škola nebo školské či vzdělávací zařízení, užije-li nikoli za účelem přímého nebo nepřímého hospodářského nebo obchodního prospěchu k výuce nebo k vlastní potřebě dílo vytvořené žákem nebo studentem ke splnění školních nebo studijních povinností vyplývajících z jeho právního vztahu ke škole nebo školskému či vzdělávacímu zařízení (školní dílo).*

³⁾ *zákon č. 121/2000 Sb. o právu autorském, o právech souvisejících s právem autorským a o změně některých zákonů (autorský zákon) ve znění pozdějších právních předpisů, § 60 Školní dílo:*

(1) *Škola nebo školské či vzdělávací zařízení mají za obvyklých podmínek právo na uzavření licenční smlouvy o užití školního díla (§ 35 odst. 3). Odpírá-li autor takového díla udělit svolení bez vážného důvodu, mohou se tyto osoby domáhat nahrazení chybějícího projevu jeho vůle u soudu. Ustanovení § 35 odst. 3 zůstává nedotčeno.*

(2) *Není-li sjednáno jinak, může autor školního díla své dílo užít či poskytnout jinému licenci, není-li to v rozporu s oprávněnými zájmy školy nebo školského či vzdělávacího zařízení.*

(3) *Škola nebo školské či vzdělávací zařízení jsou oprávněny požadovat, aby jim autor školního díla z výdělku jím dosaženého v souvislosti s užitím díla či poskytnutím licence podle odstavce 2 přiměřeně přispěl na úhradu nákladů, které na vytvoření díla vynaložily, a to podle okolností až do jejich skutečné výše; přitom se přihlédne k výši výdělku dosaženého školou nebo školským či vzdělávacím zařízením z užití školního díla podle odstavce 1.*

ABSTRAKT

Předložená práce se zabývá implementací moderních experimentálních metod popisujících lomové chování pryže v těsnících aplikacích pro dosažení zefektivnění procesu vývoje gumárenských směsí pro tyto aplikace. V teoretické části byla popsána problematika těsnících aplikací na vybraných praktických příkladech. Pro experimentální část práce byla zvolena gumárenská směs s variací typů pryže a vulkanizačního činidla tak jako množství plniva a změkčovadel. Tyto směsi byly nejdříve podrobeny základním analýzám pro popis standardních mechanických vlastností. Nejrozsáhlejší část práce je poté zaměřena na implementaci experimentálních metod pro popis lomového chování pryže při simulaci reálného zatěžování těsnících prvků. Pro tyto analýzy byly zvoleny metody charakterizace minimální energie potřebné pro vznik a šíření trhliny tak jako metoda stanovení rychlosti šíření trhliny při cyklickém únavovém zatěžování. Výsledky prokázaly jednoznačný přínos implementace těchto metod do procesu vývoje gumárenských směsí a to jak pro efektivitu samotného vývoje při minimalizaci nákladů tak jako pro stanovení životnosti a tím efektivnějším dimenzování těsnících prvků při návrhu jejich aplikací.

Klíčová slova: pryž, kaučuková směs, lomová mechanika, lom, únava, těsnící aplikace, mechanické zatěžování, dynamické zkoušky, iniciace trhliny

ABSTRACT

This thesis deals with the implementation of modern experimental methods describing the fracture mechanism of rubber-like materials in sealing applications to achieve a more efficient development of rubber compound for these applications. In the theoretical part the problem of sealing applications was described on selected practical examples. For the experimental part, a rubber blend was chosen with a variety of rubber and vulcanizing agents as well as an amount of fillers and softeners. These mixtures were first subjected to basic analysis to describe standard mechanical properties. The most extensive part of the thesis is focused on the implementation of experimental methods for the description of the breaking behavior of rubber in the simulation of the real loading of the sealing elements. For this analysis, the minimum energy characterization techniques required for crack initiation and propagation were chosen, as well as the method of determining the crack growth rate prop-

agation during cyclic fatigue loading. The results showed a unique contribution of the implementation of these methods in the development of rubber compounds, both for the efficiency of the development itself, while minimizing the costs as well as for determining the fatigue lifetime and thus the more effective dimensioning of the sealing elements in the design of their applications.

Keywords: rubber, rubber compound, fracture mechanism, fracture, fatigue, Sealing application, mechanical loads, dynamic tests, crack initiation

ACKNOWLEDGEMENTS

I would like to express my gratitude to my supervisor Ing. Radek Stoček Ph.D. for the useful comments, remarks and engagement through the learning process of this master thesis. Furthermore I would like to thank to Ing. Jakub Kadlčák Ph.D. and to Datwyler company.

I hereby declare that the print version of my Master's thesis and the electronic version of my thesis deposited in the IS/STAG system are identical.

CONTENTS

INTRODUCTION	11
1 SEALS AND SEALING APPLICATION.....	13
1.1 PRINCIPLE OF SEALING FUNCTION	14
1.2 REQUIRED MATERIAL PROPERTIES.....	16
2 RUBBER COMPOUND FOR SEALING APPLICATION.....	19
2.1 RUBBER.....	19
2.1.1 Nitrile butadiene rubber (NBR)	20
2.1.2 Chloroprene rubber (CR)	20
2.1.3 Silicone rubber	21
2.1.4 Fluoroelastomers (FMK).....	21
2.1.5 Ethylene propylene diene rubber (EPDM).....	22
2.2 INGREDIENTS.....	23
2.2.1 Vulcanization system	23
2.2.1.1 Vulcanizing agents.....	23
2.2.1.2 Accelerators	24
2.2.1.3 Activators of vulcanization.....	25
2.2.1.4 Vulcanization retarders	25
2.2.2 Filler	25
2.2.2.1 Carbon black	25
2.2.3 Plasticizing agents	28
2.2.4 Antidegradants	28
2.2.5 Softeners.....	28
2.2.6 Special Ingredients	28
2.3 MIXING OF COMPOUND.....	28
2.3.1 Double-roll mill.....	29
2.3.2 Internal mixer	30
2.4 VULCANIZATION	30
3 FATIGUE AND FRACTURE MECHANISM.....	33
3.1 FATIGUE LIFE	33
3.2 FATIGUE CRACK INITIATION	34
3.3 FATIGUE CRACK PROPAGATION	35
3.3.1.1 Energy required to grow a crack.....	36
3.3.2 Fatigue during dynamic loading.....	38
3.3.3 Description of mechanical loading.....	39
3.4 FATIGUE OF EPDM	40
3.4.1 Effect of mechanical loading	40
3.4.2 Effect of carbon black loading	40
4 PREPARATION OF SAMPLES	43
4.1 RUBBER COMPOUND RECIPES	43
4.2 PREPARATION OF COMPOUNDS	43
4.3 CHARACTERIZATION OF RHEOLOGICAL PROPERTIES	44
4.4 PREPARATION OF TESTING SPECIMENS.....	45
5 EXPERIMENTAL METHODS.....	46

5.1	BASIC MATERIAL CHARACTERIZATION	46
5.1.1	Hardness test	46
5.1.2	Tensile test	46
5.2	ADVANCED MATERIAL CHARACTERIZATION.....	47
5.2.1	Intrinsic Strength Analyzer	47
5.2.1.1	Boundary conditions of analysis.....	49
5.2.2	Tear and fatigue analyzer	50
5.2.2.1	Boundary conditions of analysis.....	51
6	RESULTS AND DISCUSSION.....	53
6.1	HARDNESS TEST	53
6.2	TENSILE TEST	53
6.3	INTRINSIC STRENGTH ANALYSIS	54
6.4	FATIGUE CRACK GROWTH ANALYSIS	56
6.5	IMPORTANCE OF RESULTS FOR SEALING APPLICATIONS	61
	CONCLUSION	62

INTRODUCTION

Because of the increasing technological progress, higher demands on material and its cost, it is necessary to use state-of-the-art technologies and materials. This concerns the space application as well as and sealing applications, which are often overlooked.

Sealing applications are essential and indispensable components of modern machinery and devices. Seals are used in every kind of industry. Although the seals are the most demanding in respect to material properties, their price is in units of cents, while the machines in which are used, cost hundreds or up to thousands of euros. It might seem like there is no need to put high demands on such a cheap part of machine. However, gaskets are usually placed at an inaccessible location in the machine, and failure may cause not only the malfunction of the machine, but also its failure or eventual destruction with fatal consequences.

An example of a fatal seal failure can be a disaster of space shuttle Challenger. When the destruction of the O-ring on the rocket engine was the cause of its destruction at the space shuttle take-off.

It is not only important to prepare material with optimal mechanical properties and chemical resistance, but also to monitor its fatigue behavior and to predict its service life. So, in the best case, service life of the seal is the same as the service life of the machine, or eventually it is crucial to be aware of its service life and replace it before the end of its end.

The fatigue behavior of rubber is currently a decisive material parameter, despite the fact that it was still described very little due to the large number of components of the rubber compound and the high demands on the computing technique and the devices for its monitoring.

I. THEORY

1 SEALS AND SEALING APPLICATION

The seals are the component that serves to seal and prevent the flow of liquids and gases through the gap between the components since it is very difficult to produce, for example, machine parts that would perfectly touch each other on the entire surface. This contact may be undesirable in many cases, but this issue will be described later.

The seals can be made of many materials that differ in their properties and applications. The materials used to make the seals are metals, paper, textiles, cork, rubber. Especially the last one, rubber, is a very suitable material for sealing applications. A great advantage of rubber compared to other materials is its high elasticity, which makes the rubber seal not only seal the gap but also absorb vibrations.

Seals can be found wherever they work with liquids or gases, that is, in every machine, tool, product, industry, everywhere in everyday life. The seals are used in very simple machines and even in very complex and expensive machines, the operation of which would not be possible without sealing.

The seal can take many forms, examples of seals are shown in Figure 1, for example, O-rings, gasket or differently shaped profiles. [1]

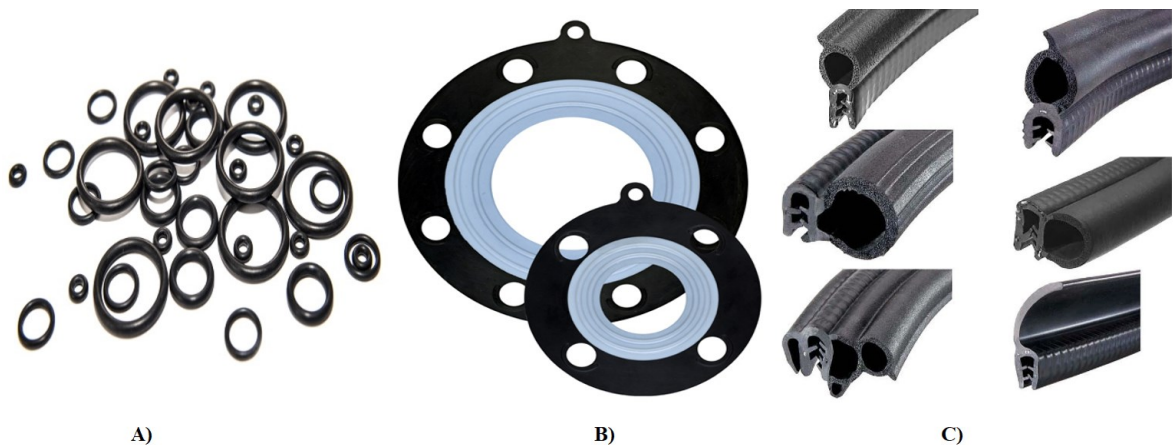

Figure 1: Seals; A) O-ring; B) Gasket; C) Profile-shaped seal [2,3,4]

The sealing in machines have not only the role of sealing but also a role of a vibration absorber. This role is mainly used in automotive industry where seals are used not a static seal (for example, around the window frame), as well as in the powertrain and braking systems. The examples are shown in Figure 2.

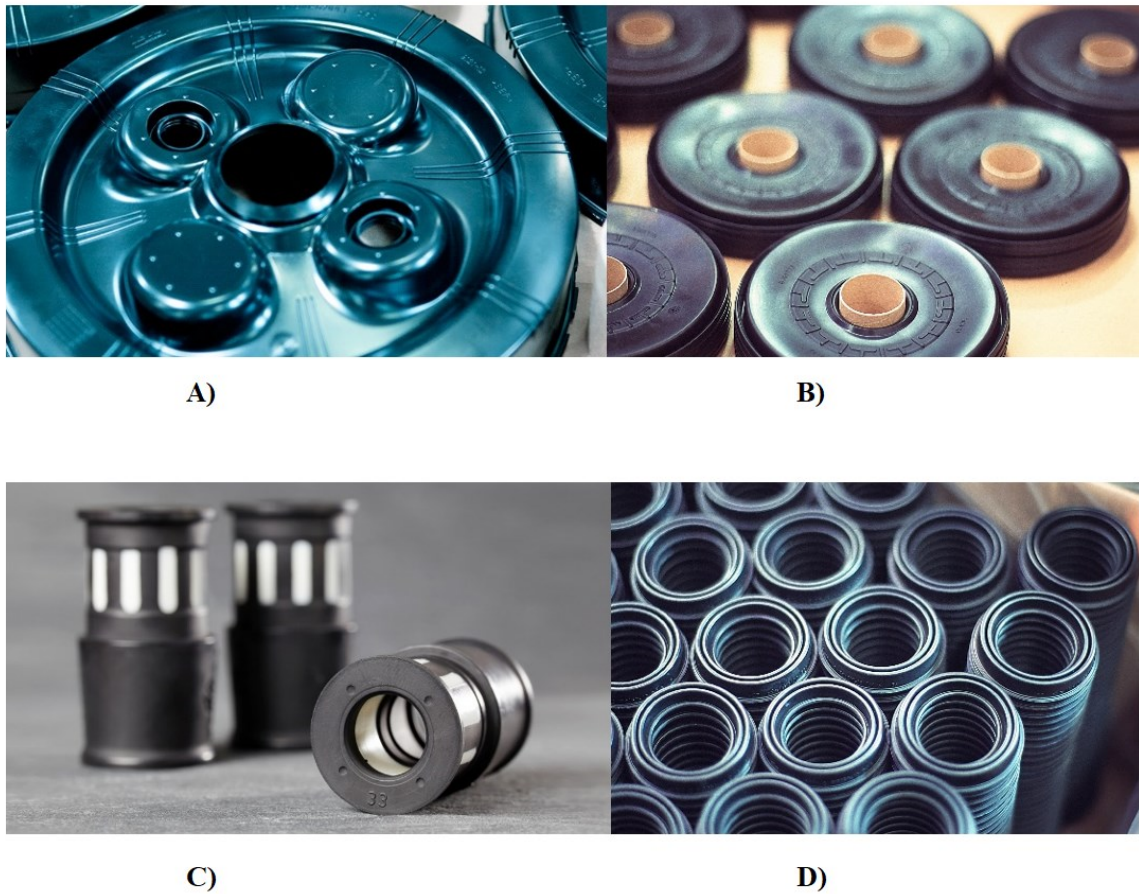

Figure 2: Seals; A) Diaphragm for brake booster; B) Diaphragms; C) Caliper for Disc-Brake; D) Piston protection cap [5]

1.1 Principle of sealing function

The principle of the seal function will be described for the simple case - the O-rings. O-rings are typically statically loaded but they can be also used in dynamic load applications.

Figure 3 shows an O-ring located in the groove in the unloaded state. In order for the O-ring to fulfill its role, it is necessary to load it. Deformation of the O-ring due to load is usually between 7 and 30%, varies for individual applications. [1]

Figure 4 shows the O-ring when we applied the load. The O-ring is deformed and perfectly seals the groove. Because it is an elastic material, the O-ring is deformed and seals the groove. It is important that only elastic deformation occurs rather than plastic deformation, although plastic deformation occurs, but to a very limited extent.

Figure 5 shows an O-ring at the applied pressure of the liquid.

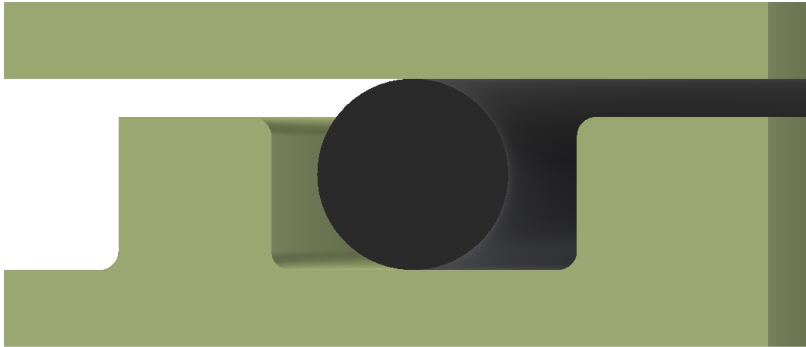

Figure 3: Scheme of O-ring in the groove

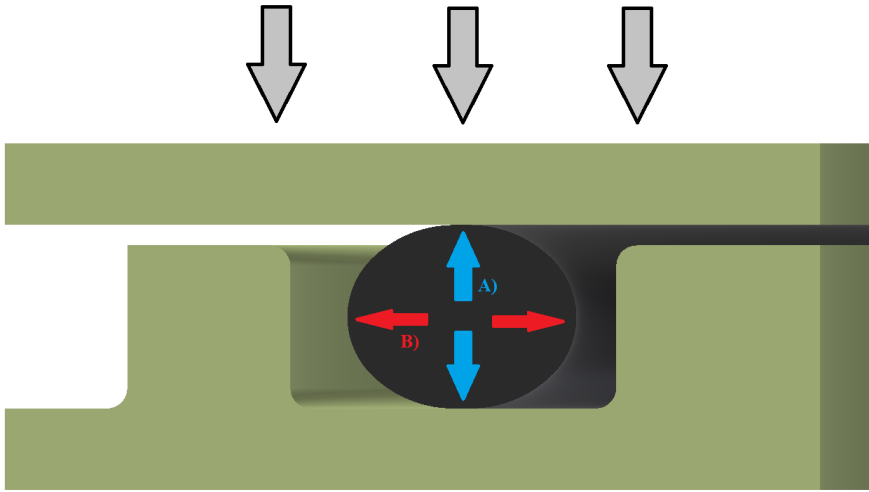

Figure 4: Scheme of function of O-ring, A) Interference force created by compression in the groove; B) Deformation of the O-ring due to compression

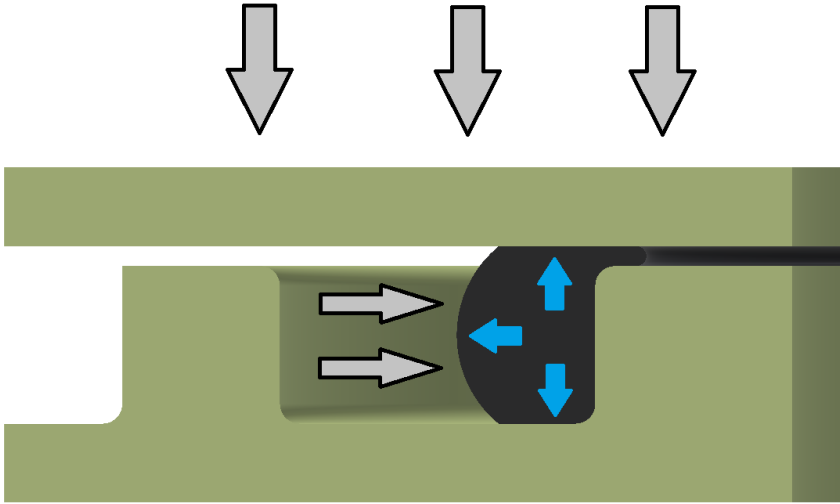

Figure 5: Scheme of function of O-ring at applied liquid pressure

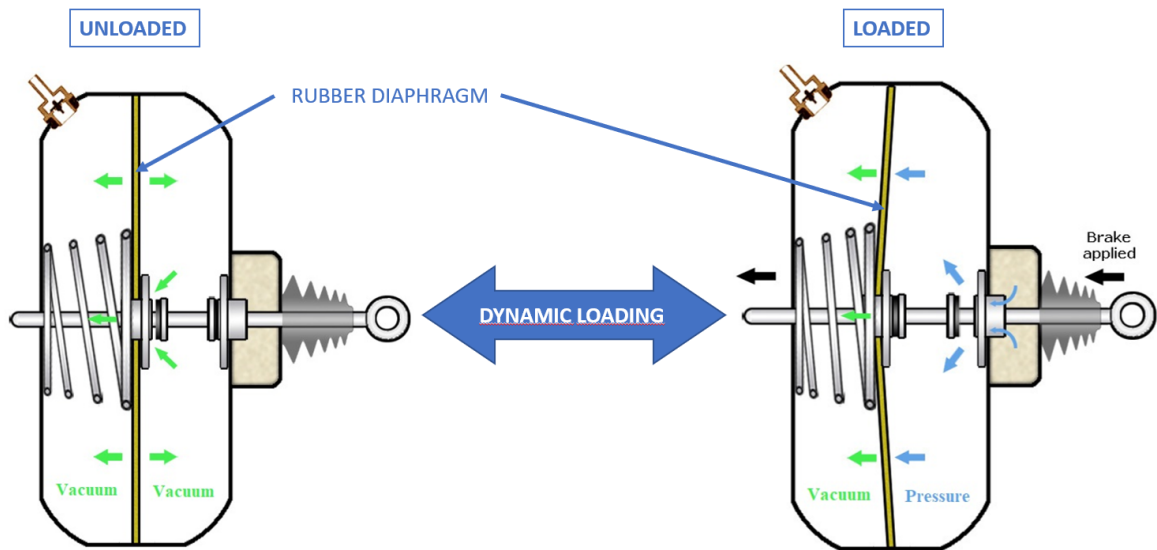

Figure 6: Vacuum brake booster at rest (left) and in use (right) [6]

The second example is diaphragm for brake booster (Figure 6 and Figure 2 A)). Most of Brake boosters, have two or more chambers, divided by flexible diaphragms. The chamber is usually steel and the diaphragm has rubber qualities. They attach a metal push rod to the diaphragms and it moves with them. Vacuum, usually supplied by the engine and atmospheric pressure combine to provide the assistance during braking.

The figure 6 (the left side) shows the brake booster in a rest position, where the same pressure (vacuum) on the both sides of diaphragms and is maintained by a two-way valve.

However, if the brake pedal is depressed (Figure 6 right side), we start to move the shaft to the open position and the air flows to the right side. Differential in pressure created braking.

When we compare the O-ring and the brake booster diaphragm, there is a large difference in wear between them, even though the O-ring function has been introduced very generally and depends on the particular application. The O-ring is loaded rather statically, on the other hand the diaphragm is loaded dynamically, resulting in faster wear and shorter fatigue life.

1.2 Required material properties

From the explanation of the principle of sealing function, it is possible to infer what properties are required for the material from which the seal is made. Important properties that material must meet in our case is elasticity, temperature resistance, chemical resistance, resistance to permanent deformation, resistance to crack initiation followed by fatigue crack growth.

As mentioned above, the seals are dynamically loaded, and the load causes irreversible changes in the rubber. Although these changes are not at first glance visible, they can not be considered as unimportant, just the opposite. When the rubber is loaded, either chemical or physical bond breaking occurs in rubber (Mullins [17] and Payne effect), then each interruption of the bond means the formation of a crack (microcrack). This microcrack can grow to such a degree, that it causes the seal to fail. Figure 7 (right) shows cracks typical of ozone degradation but accelerated by mechanical loading.

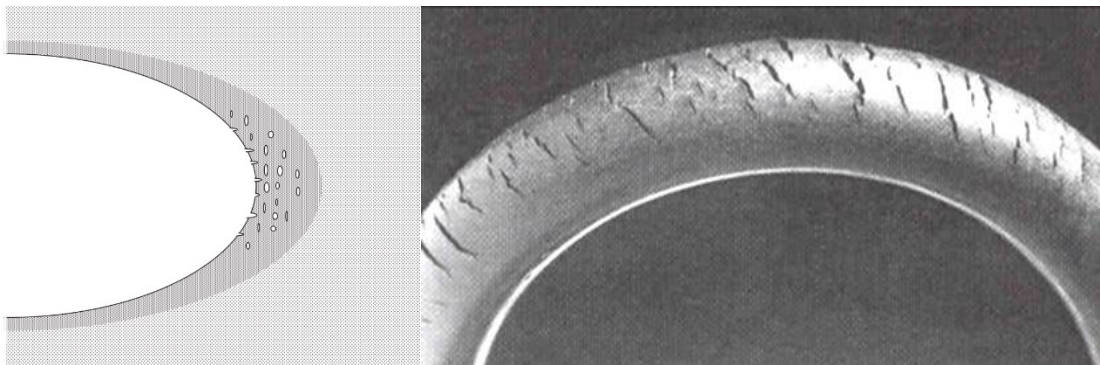

Figure 7: Microcrack in the crack tip (left); crack on the surface of O-ring (right)
[7,8]

Elasticity is important based on the required sealing, since if there is a plastic deformation and consequently a decrease in the load, an undesirable gap would occur between the seal and the component.

Because the machines in which those seals are used operate at different temperature ranges from minus temperature to temperatures exceeding 100 °C. It is necessary for the material, even in such cases, not to lose its property and not to degrade.

Equally important property is the chemical resistance. The seal may be subjected to a variety of operating fluids, whether polar or non-polar and should be resistant to their operation.

Last but not least, it is important to mention resistance to crack initiation and fatigue crack growth. Fatigue cracks can arise both in the static and primarily in the dynamic loading, which can lead to destruction of the seal, that can damage the machine in which the seal is located. It is therefore important to know fatigue life for the material.

Seals usually occur in a machine in a very poorly accessible places, and in particular in the automotive industry, the whole component, not just the seal, is changed when it fails. Therefore, the damage caused by the failure of the seals is in the hundreds of EUR, not just the cents, as is the price of seals. It is therefore necessary to know and predict the fatigue life of

the seal. It is important to use the most modern technologies to predict lifetime, which will be described in the following chapters.

2 RUBBER COMPOUND FOR SEALING APPLICATION

The Second chapter will discuss the design of compounds for sealing applications. The individual ingredients of the compound and their role in the rubber compound will be described.

The rubber compound is composed of many components that fulfill a different role in the compound. The basis of the compound is rubber, which carries the essential properties. An important component of the compound is the vulcanization agent, which gives us from a soft, flexible material without more industrial use, a strong, elastic material with excellent properties. These properties can be further modified, for example, by adding a filler. In addition, various oils and lubricants are added to the mixture which, on the one hand, allow for better blendability of the compound, allows the use of a higher filler content, improves the dispersion of the filler, but also softens the material. If we already have the proposed compound with the required properties, it is necessary to ensure that the compound remain intact throughout its working, so antidegradants are added to the mixture to prevent degradation processes. Degradation may occur due to the weather, heat, but also due to operating fluids that are in contact with the compound when applied.

The rubber compound intended for sealing applications has its own specificities and these are given by a specific application. It is therefore important to know for what environment the compound is being prepared, whether it will be exposed to UV radiation, polar or non-polar substances, exposed to high or low temperatures. An equally important component in designing a compound is the knowledge of what kind of load the compound will be exposed to. Whether its purpose is merely to seal a space (possibly to transport chemicals) or to act as a silencer. All of these criteria are important for compounding. [9,10,11]

2.1 Rubber

As has been written above, rubber is the essential component of the compound and the carrier of the essential properties. These basic properties include its chemical resistance and weather resistance, its temperature range of application and, last but not least, its mechanical properties.

For sealing applications, EPDM, NBR, Silicone Rubber and CR rubber, and others, are the most used. Each of the mentioned rubber stands out and its application is in another type of seal. [1,9]

2.1.1 Nitrile butadiene rubber (NBR)

NBR rubber is most commonly used where sealings come into contact with gasoline, oils and lubricants.

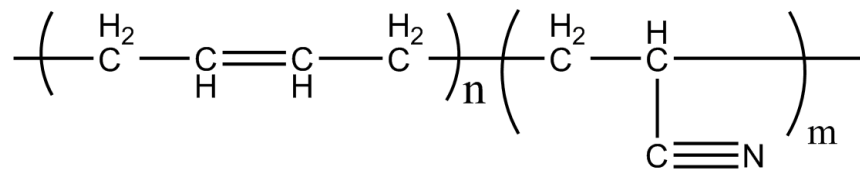

Figure 8: Nitrile butadiene rubber [12]

NBR rubber is produced by radical copolymerization in the emulsion. The rubber formed in his way contains 18-49% acrylonitrile. The content of acrylonitrile greatly affects its oil resistance. NBR rubber also has excellent tensile and bending properties. The acrylonitrile content also has an effect on the glass transition temperature and hence on the temperature range of use, where the increase in acrylonitrile content by 1% increases the glass transition temperature by 1.5 °C [2,4], and increases the hardness and loss of elasticity. Thus, it is necessary to find the appropriate acrylonitrile content so that the selected rubber meets the necessary thermal constraints and also has optimal mechanical properties. NBR usually has a temperature range from -54 °C to 121 °C. As already mentioned, it very well resists oils, gasoline and lubricants. It also excels in its abrasion resistance and crack resistance. It is often used in the presence of nitrogen and helium.

NBR also has its disadvantages among which are low resistance to UV radiation, ozone and weathering, and it resists the action of ketones, chlorinated hydrocarbons.

Its most common applications include fuel handling applications in the aerospace and automotive industries. [9,10,11,13]

2.1.2 Chloroprene rubber (CR)

Chloroprene rubber is formed by the radical polymerization of chloroprene, predominantly in the emulsion. CR can be prepared in several modifications that have different properties. [9,13]

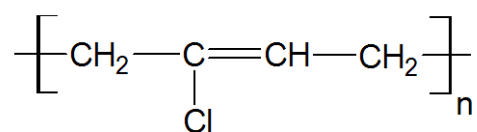

Figure 9: Chloroprene rubber [14]

The temperature range for the CR is from -40 °C to 138 °C. However, in the long term, it can withstand at most 90 °C and at low temperatures around -18 °C it starts to hard and below -40 °C becomes brittle. [13]

CR is polar rubber. Its polar character allows it to withstand oils, oil products, lubricants, and on the contrary, has very low resistance to strong acids, esters, ketones, and chlorinated and aromatic hydrocarbons.

Its main strengths include excellent water resistance, good resistance to moderate ozone, UV radiation, weather and resistance to non-polar substances.

It is also capable of crystallizing under tension, which gives it good dynamics of properties and strength even in non-filled compound. [9,10,13]

CR is currently being replaced by EPDM.

2.1.3 Silicone rubber

The silicone rubber has the bond -Si-O- in main chain. Silicone rubbers are several species, each with a slightly different use [9].

Generally, the great advantage of silicone rubber is its large temperature range of use. When can be used for a long term at 205 °C. They are typically used in the range of -60 °C to 180 °C. They also excel in their resistance to ozone and weather. They have excellent el-isolation properties and good fire resistance. [13]

However, these advantages are compensated by a number of disadvantages, namely low resistance to acids, alkalis and other liquids. Resistance to liquids can be increased by fluorine atom modification. Another major disadvantage of silicone rubber is its very low structural strength and generally being not suitable for dynamic loading applications.

Silicone rubber is still used in a variety of applications in aerospace, space industry, medicine, food and automotive especially in ignition cables. [1,9,10,13]

2.1.4 Fluoroelastomers (FMK)

The group of fluoroelastomers includes a number of fluorine-containing copolymers. When the C-F bond provides good thermal and chemical resistance.

FMK excels with its high temperature resistance up to 316 °C for 48 hours, however,

during dynamic stresses can only be used up to $-20\text{ }^{\circ}\text{C}$. static loading can be used even at lower temperatures. [13]

FMKs also have good chemical resistance to oxidation, ozone, fuels, oils and concentrated acids. However, they swell in some polar solvents (ethers, esters and ketones)

A disadvantage may be its relatively high density, which is 1.8 g/cm^3 .

FMKs are most commonly used as the inner layer of fuel hoses and exhaust pipe seals. [1,9,10,13]

2.1.5 Ethylene propylene diene rubber (EPDM)

EPDM is a copolymer of ethylene, propylene and the third monore is diene thanks to which it can be vulcanized with sulfur. As a diene was, most of the time used ethylidene norbornene. The advantage of EPDM is also its very low density of about 0.9 g/cm^3 compared to CR whose density is about 1.24 g/cm^3 .

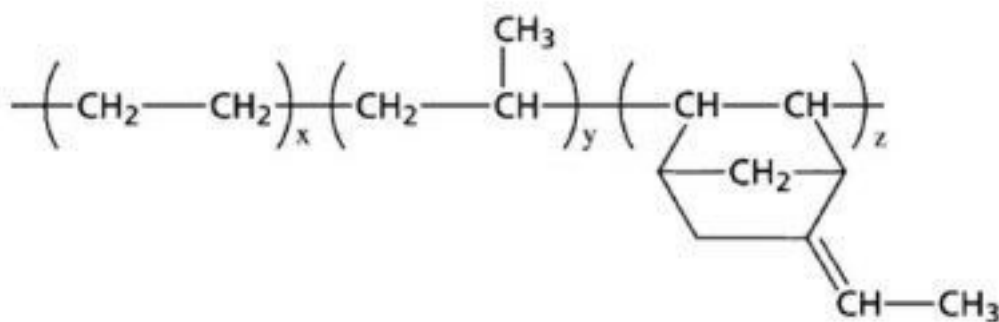

Figure 10: EPDM rubber [15]

EPDM is most commonly used in applications where the seal is exposed to low or high temperature and weathering. Its temperature range is from $-60\text{ }^{\circ}\text{C}$ to $150\text{ }^{\circ}\text{C}$. EPDM can be used for long time at temperatures from 126 to $150\text{ }^{\circ}\text{C}$. [13]

EPDM has a very good resistance to low and high temperatures. It also has excellent resistance to ozone and weather. It is also an excellent electrical insulator, which allows it to be used to cover cables. Due to its nonpolar character, it has very good resistance to polar substances such as ketones, dilute acids and alkalis, and is resistant to steam. Non-polar character, however, carries a negative and it is its poor resistance to non-polar substances such as oil, gasoline, kerosene, aliphatic hydrocarbons. It is also non-resistant to halogen solvents and concentrated acids.

EPDM is capable of crystallization. The ability to crystallize is affected by the content of ethylene, with the content of ethylene increasing the crystallinity. EPDMs with an ethylene content of less than 62% are referred to as amorphous and with a content greater than 62% as semi-crystalline. Amorphous types have relatively low hardness and high elasticity even at lower temperatures, whereas semi-crystalline types have a higher hardness and are less resistant to permanent deformation. The ability to crystallize greatly affects the mechanical properties and at the same time contributes to greater fatigue resistance.

EPDM is most commonly used in applications where long-term low temperatures are still present in the automotive industry for cooling and weather-stripping applications.

As written above, the EPDM replaces the CR in its present day due to its good properties. Better resistance, both chemical, thermal and even better mechanical properties. EPDM Despite its big advantages, can not be used as a substitute for NBR due to its nonpolar character. In comparison with silicone rubber, the heat resistance of EPDM is worse, but the mechanical properties of EPDM are great advantages. EPDM rubber also has the lowest density of rubber listed above. [1,9,10,13]

2.2 Ingredients

There are many kinds of ingredients that differ in their task. The aim of the ingredients is to optimize the properties of the compound. The amount of ingredients in the compound is given by the phr unit (number of parts per hundred pieces of rubber) [9]

2.2.1 Vulcanization system

The function of the vulcanization system is to modulate the polymer by forming crosslinks (bridges) between the chains. The vulcanization system consists of a vulcanizing agent, an accelerator, an activator and an inhibitor. It is added to the mixture in phr units. [9,10]

2.2.1.1 *Vulcanizing agents*

The vulcanizing agent is the main component of the vulcanization system. The most important and most used reagent is elemental sulfur. Sulfur is only applicable to unsaturated rubbers. Metal oxides, reactive resins, dialkyl and diacyl peroxides and other. [9,10]

2.2.1.1.1 Sulfur

Sulfur is a basic component of sulfur vulcanization systems. A condition for its use is the presence of unsaturated bonds. Sulfur vulcanization itself would take hours, so it must be used together with activators and accelerators.

Sulfur vulcanization systems allow for extensive control of vulcanization kinetics, and allow for freedom to the design of the recipe. It is also possible to control the length of the sulfur crosslinks. Sulfur vulcanizates also have good properties in dynamic loading. [9]

2.2.1.1.2 Peroxides

Peroxides are mainly used in unsaturated rubbers that cannot be vulcanized with sulfur. Peroxide vulcanization works on radical mechanism.

A major advantage of peroxides is that there is no vulcanization during storage and high rate of vulcanization at high temperatures. The disadvantage of using peroxides is the undesirable reaction with other ingredients, the difficulty with setting the ration of scorch time/ vulcanization rate, the long times of vulcanization at low temperatures, high peroxide price.

Rubber vulcanized by peroxides exhibits low permanent deformation, tensile strength, crack growth and abrasion resistance and also high heat resistance, which suggests that peroxides are more suitable for sealing applications [9]

2.2.1.2 Accelerators

The accelerator function is accelerating the vulcanization process, but also increasing the efficiency of the sulfur bonding, resulting in improved properties of the vulcanizate, especially resistance to aging and resistance to higher temperatures. [9,10]

As accelerators are used:

- Slow-amines, guanidines
- Fast - thiazoles, sulfaamides
- Very fast - tiuramy
- Ultra-accelerators - xanthates and dithiocarbamates

2.2.1.3 *Activators of vulcanization*

Activator function is, as with accelerators, to increase the efficiency of sulfur binding and to reduce the rate of vulcanization to temperature. Activators include stearic acid, ZnO and others. [9,10]

2.2.1.4 *Vulcanization retarders*

Retarders increase processing time at processing the mixture.

As Retarders are used:

- Inorganic retarders - MgO, PbO
- Organic retarders - Sodium acetate, sebacic acid, adipic acid, anhydrides and other substances [9,10]

2.2.2 **Filler**

Fillers are used in rubber mixtures for two reasons. The first reason is to adjust the workability and physical-mechanical properties. The second reason is to lower the price of the product. For these reasons, most mixtures are filled. Vulcanized fillers create many places where friction can occur at the rubber / filler interface, which results in energy conversion and the material is not easily disrupted. Fillers are mostly powdery solids of solid consistency. In mixtures, they are in a high concentration of 50-100 phr. [9,10,13]

Fillers are classified according to their effects on the properties of the vulcanizate:

- a) Reinforcing - increases tensile strength, structural strength, abrasion resistance (fine particles, precipitated silica)
- b) Semi-reinforcing - increases tensile strength, structural strength, but do not improve abrasion resistance (coarse carbon black, hard kaolin, precipitated CaCO₃)
- c) Non-reinforcing - does not improve the properties of vulcanizate (talc, soft kaolin, CaCO₃) [9]

2.2.2.1 *Carbon black*

Carbon black is one of the most used fillers in the rubber industry. It is used for its reinforcing effect. Can also be used as a dye, UV stabilizer, affect electrical properties and thermal conductivity.

Carbon black is produced by the partial combustion of organic matter in the gas phase. Thermal decomposition of organic compounds results in C₂-C₄ radicals which are recombined into cyclic structures in the liquid state. Initial small droplets (2 - 5 nm) are joined in greater and more stable (10 - 20 nm), which subsequently burn to dendritic aggregates. [9]

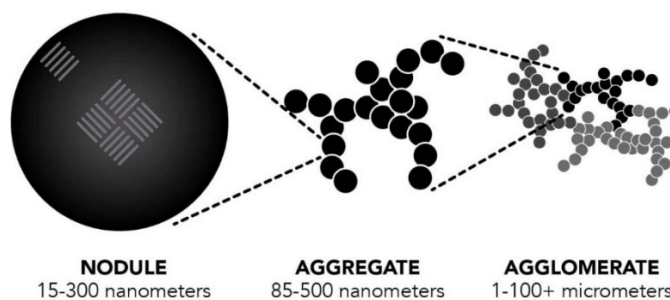

Figure 11: Carbon black [16]

Depending on the raw materials, additives and production conditions used, carbon blacks are produced with different particle sizes and different morphology of carbon black aggregates.

The most important characteristics that they are divided into are:

- Particle size (specific surface area)
- Particle Structure (DBP Absorption)
- Chemical composition and energy ratios on the surface of the particles (surface activity)

Besides carbon, common types of carbon black also contain various impurities. For example, large particles from the reactor lining and other. Important for the quality of the carbon black is the moisture content, the content of the various substances which can be extracted with toluene and the sulfur content. [9,10]

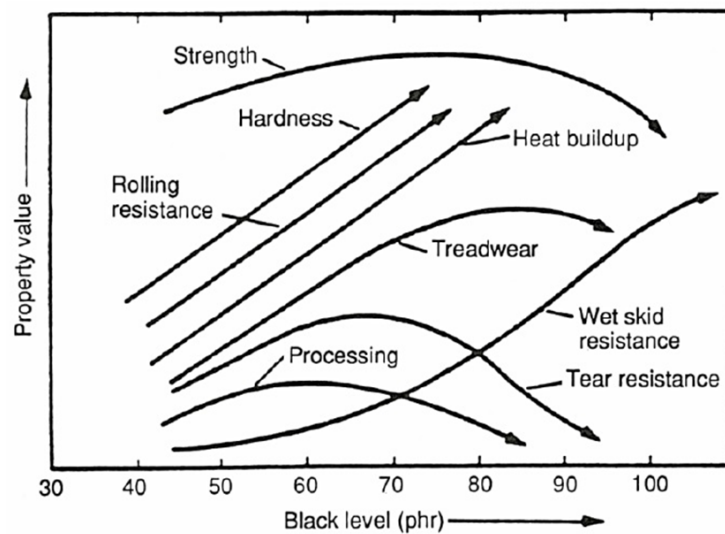

Figure 12: Effect of carbon black volume on compound properties and final rubber behavior [36]

Figure 12 shows the changes in the values of the basic material parameters in relation to the carbon black content. This figure can serve as a very useful assistant in assembling a rubber recipe with carbon black.

In sealing applications, especially carbon blacks are used N550, N330, N762 and N774.

2.2.2.1.1 N762 and N774

It is a soft carbon black with medium activity. They provide a high mechanical resistance and improve mechanical properties. However, they have a low surface and therefore, compared to higher surface carbon black (N550), their improvement was poor. They are mainly used to reduce the heat generated during mixing. [9,10,13]

2.2.2.1.2 N330

N330 carbon black gives the vulcanizate a good abrasion resistance and good tensile properties, resulting in excellent tensile strength, crack resistance and good elasticity. It also has good dispersion. They are used for rubbers that require very good mechanical properties. [9,10,13]

2.2.2.1.3 N550

N550 has a smooth particle surface and a high structure, resulting in the best results in the soft carbon black category. N550 is very well mixed and dispersed. The vulcanizate filled by N550

have a high service life, high temperature resistance, high elasticity, and manufacturing reflectivity. Together with N330 carbon black the N550 is mostly used in sealing applications. [9,10,13]

2.2.3 Plasticizing agents

Plasticizing agents are ingredients, which accelerate process of plasticization of rubber. As plasticizing agent are used for example, aromatic mercaptans and their salts, disulfides, phenols, organic acids and their salts and other substances. [9,13]

2.2.4 Antidegradants

The degradation of vulcanizate can be caused by a number of influences, such as the effects of oxygen, heat, ozone, mechanical stress, UV radiation.

Antidegradants divide into:

- a) Antioxidants and antiozonants
- b) UV absorbers
- c) Protective waxes
- d) Functional group hydrolysis inhibitors [9,10]

2.2.5 Softeners

These are low-molecular substances, mostly oily products from crude oil processing, coal tar, or also synthetic plasticizers (ester, ether, polymeric plasticizers). There are several reasons for using plasticizers. One of the reasons is that with a high concentration of fillers in the mixture, even in the unvulcanized state, very high stiffness can occur, in which the processability is very difficult. Other reasons are improvement of dispersion of fillers and additives, modification of physical-mechanical properties. [9,10,13]

2.2.6 Special Ingredients

Additional ingredients are added to blends to achieve special properties. These include blowing agents, pigments, interrupters, antistatic agents. [9,10]

2.3 Mixing of compound

The mixing process is at least equally important for the resulting properties of the mixture, such as stock-mixture. Mixing must ensure a uniform distribution of ingredients throughout the mixture.

The mixing process is complicated by the heterogeneous character of the individual components of the mixture. For example, rubbers that behave like subcooled caps at temperatures around 25 ° C, their viscoelastic behavior, which is highly temperature dependent, is projected at elevated temperature. Conversely, fillers are in the form of powders which form agglomerates. These agglomerates have to be removed by running the mixing process. Additionally, additives are used in the form of liquids and pastes, which have to be incorporated into the mixture to overcome the rubber. [9,10]

The mixing process can be carried out on:

- Double-roll mill
- Internal mixer

2.3.1 Double-roll mill

The construction of the double-roll mill is very simple. It consists of two parallel rolls that are either cooled or heated. Different roll speeds (e.g., 1:1.2) and slot size between rollers are important for mixing.

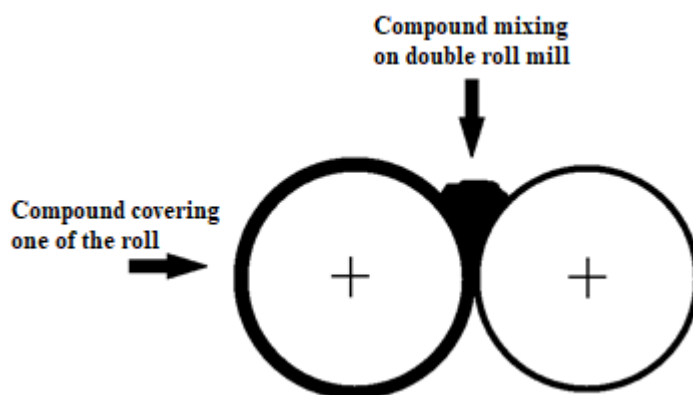

Figure 13: Double-roll mill

In this slot, the compound is mixed so that the blended compound is covering one of the rolls and generates a high shear stress (intense mixing) at the same time in the slot. When mixing on a double-roll mill, it is important to cut and fold back the mixture. At present double-roll mills are used in the laboratory or for mixing small batches of compounds.

The main disadvantages of double-roll mill mixing include long mixing time, poor repeatability, the need for a qualified operator. The advantages is achieving high shear stress. [9,13]

2.3.2 Internal mixer

The internal mixer is composed of two rotors that are stored in the chamber. The filling opening of the chamber closes the pressure piston, which generates the pressure. The walls of the chamber are cooled. Even here the rotors move at different speeds as in a double-roll mill.

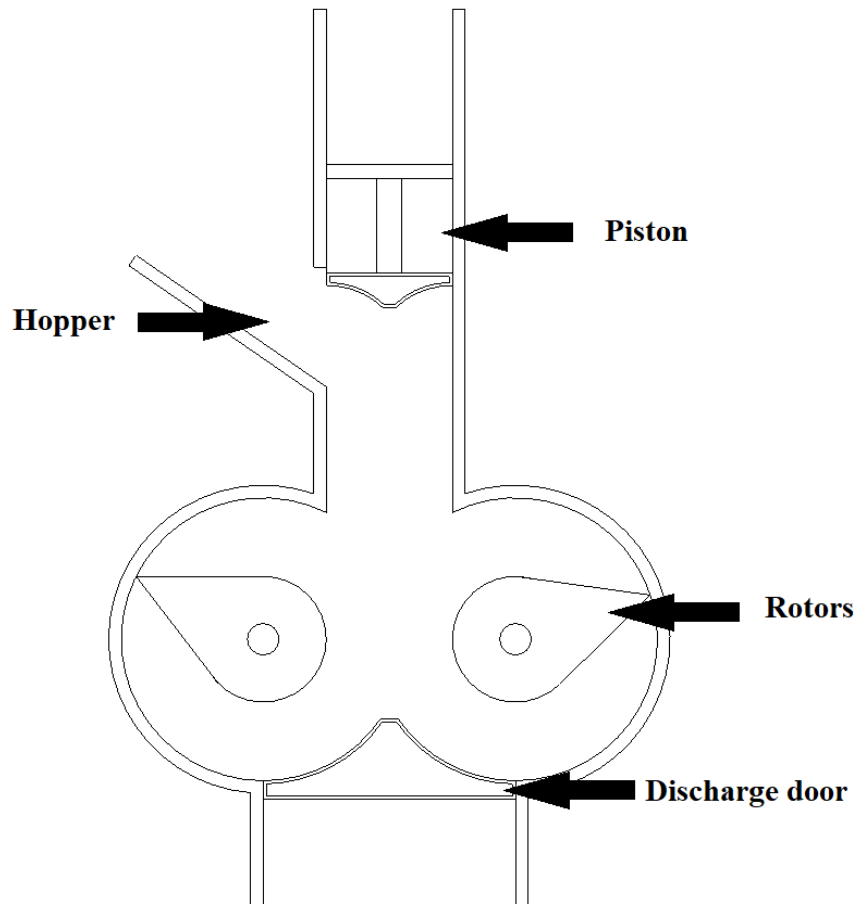

Figure 14: Scheme of internal mixer

The main advantage of mixing on the internal mixer is good repeatability, very fast mixing times, low demands on machine operation and the possibility of mixing large batches. Disadvantages include a large increase in temperature during mixing and high acquisition costs. [9,13]

2.4 Vulcanization

Vulcanization is a process in which cross-linkages are formed between the rubber chains. The formation of these cross-linkages made from very soft material become a very elastic material which is irreplaceable in many applications. By vulcanization, the rubber loses its

thermoplastic character as well as stickiness. The resulting properties of the vulcanizate are highly influenced by the density of the cross-links. [9,13]

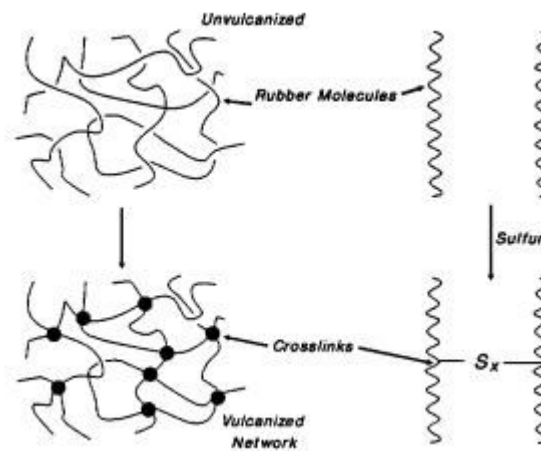

Figure 15: Sulfur vulcanization

During the vulcanization, the mechanical properties change. Especially the module and the strength increase. From the measured strength of the cure time (vulcanization curve) vulcanization can be divided into three phases (Figure 16):

- Induction and scorch - During this phase, vulcanizing agents react with rubber to form rubber-soluble intermediates. For the duration of the induction period, the mixture can be safely manipulated. At the end of this phase, transverse cross-links begin to emerge.
- Curing - the rate of cross-linking is highest and gradually decreases with the loss of vulcanizing agents. Increase in strength is highest.
- Overcuring - At this stage, networking is almost over. If the strength of the vulcanizate does not change further, it is a so-called vulcanization plateau. If the strength decreases, it is a reversion, which is typical of natural rubber. For synthetic rubbers, the strength increases above all boundaries, which is referred to as the marching module. [9,13]

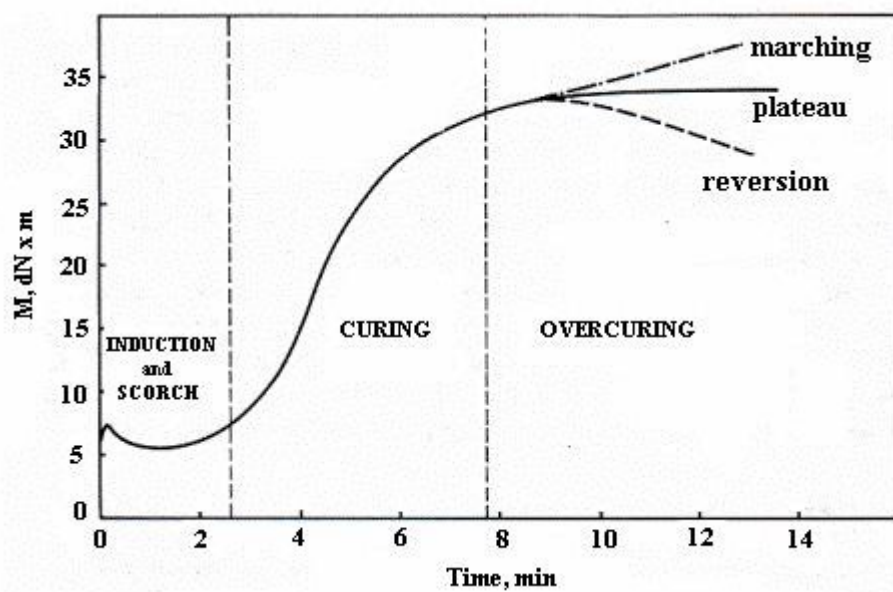

Figure 16: Vulcanization curve [18]

3 FATIGUE AND FRACTURE MECHANISM

In the previous chapters, the requirements for sealing materials and the risks posed by this application were presented. The biggest complication associated with seals is fatigue life, as its failure could, for example, be fatal in the automotive application. In the first chapter, figure 6 represents the function of a brake system booster diaphragm where failure would result in very difficult braking and at high speeds to the inability to stop the vehicle safely, for these reasons it is important to know the fatigue life of the rubber seals. The next chapter will describe fatigue, fatigue life, and factors that affect it.

Fatigue in elastomeric materials means a decrease in mechanical properties due to the occurrence and slow growth of cracks when elastomer stresses. The greatest change in properties is evident when monitoring stiffness. Fatigue is a set of many processes part of which has been described and many processes are a waiting detailed descriptions. At fatigue processes occur on the atomic and molecular level. Although these processes had been studied, they have not been fully described due to the complex structure of the rubber compound.[19]

Understanding the elastomer fatigue processes can lead to a design of more durable compound of rubber and to a prediction rubber failure.

The latest studies focus on the crack propagation during dynamic stress, parameters affecting fatigue and prediction of fatigue, tensile strength, hardness, elongation at break due to fatigue, evaluation of tearing energy and the role of filler for crack growth.

The fracture mechanics are used to the describe of nucleation of cracks and their growth. [19,20]

3.1 Fatigue Life

Fatigue life is an important characteristic for sealing applications, as mentioned in the first chapter. Fatigue life can be imagined as a time after which the seal can perform its function or also like the number of cycles at a given load needed to break the test specimen. The fatigue life is described by this dependence, ie the dependence of the stress on the number of outflows. If we plot this dependence, we are able to determine the fatigue limit, which is determined for example, a crack of a given length, a fracture of specimen or stiffness loss. In the Figure 3 shows the S/N curve. The important feature of Figure 1 is that upon reducing the dynamic stress or strain of the cycle toward a certain value, the fatigue life approaches infinity. This gave rise to the concept of a limiting stress or strain. [19]

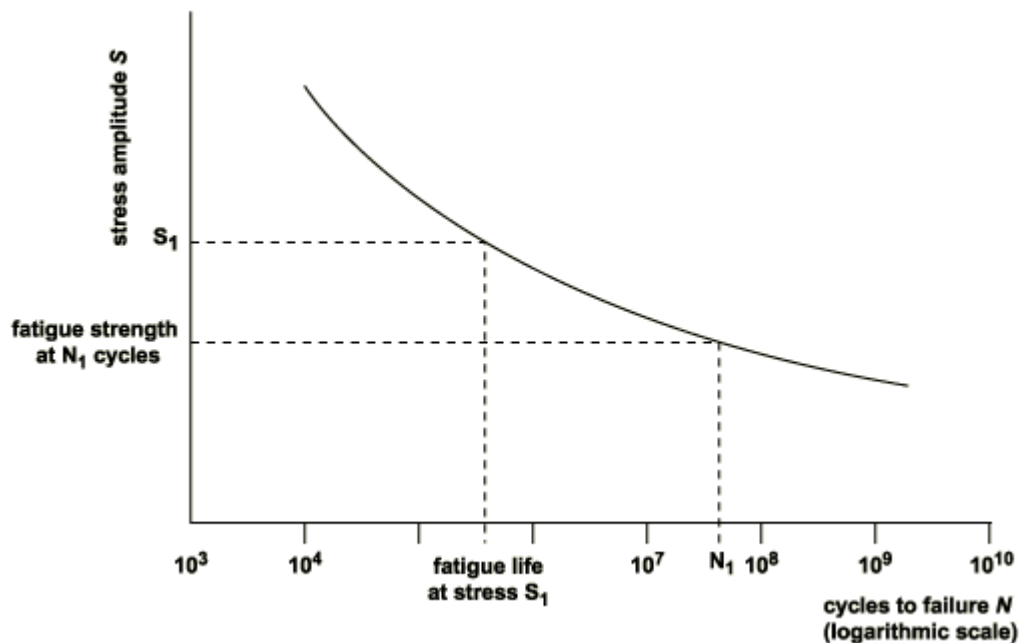

Figure 17: Wohler curve (S/N curve)

Measuring fatigue life is very challenging for two reasons. The main reason is that it is very time consuming because the number of cycles is in millions. The second reason is the need for a large number of samples. [13]

On the Wohler curve we can observe a stress decrease depending on the number of cycles. This reduction is caused by many processes for example crack initiation and crack grow. For filled fibers, this reduction is also caused by Mullins and Payne effect. [11, 14]

3.2 Fatigue Crack Initiation

The initiation crack method has not yet been fully elucidated. The basic assumption for the initiation of the crack is the presence of natural defects and inhomogeneity. These defects and inhomogeneity are present in each rubber material. Since the rubber compound contains a large number of different additives such as filler, vulcanization system, activators and other additives, many non-homogeneities occur in the material as the stress concentrator. An unavoidable part are surface fatigue cracks caused by degradation of ozone. The distinction between crack initiation and propagation has not yet been firmly established. Laboratory testing replaces the random process of initiating cracks by creating cracks for better reproducibility of tests. [11]

The crack in terms of fracture mechanics is each broken polymer chain in the plane of the crack. So, there is the minimum energy needed for broken single polymer chain. This minimum energy primarily depends on the polymer network, the length of the crosslinks and the weakest bond in the primary chain. However, it is, to some extent, independent of time, temperature and degree of swelling. This energy is called intrinsic strength, since it reflects the natures of the network and polymer chemistry. [7]

For determination of intrinsic strength of rubber is used the cutting method of Lake and Yeoh. [21,22,23]

3.3 Fatigue Crack Propagation

The theoretical description was developed by Griffith. The basic idea was that crack growth is always accompanied by increased surface. Griffith researched metal and glass materials (almost elastic materials). Griffith used the first thermodynamic law and assumed that the necessary condition for crack growth is that the energy needed to create a new crack area is delivered by the released deformation energy in the elastic body. The minimum load required to create new crack areas can be determined by the knowledge of the surface energy of the material, the crack size. Griffith also assumes that at sharp cracks arise infinite stress, and we cannot apply any load to a body with crack. [19,24]

For rubber-like materials, strength can be characterized by the amount of energy G that is required to advance the plane of fracture by one unit of area. Energy G includes not only the energy needed to break the bonds at the tip of the crack, but also the energy that dissipated near the crack during its propagation. For rubber-like materials, energy G also includes visco-elastic energy scattering, which occurs several millimeters from the tip of the crack. Experiments [25,26,27] and theory [28,29] have shown that G depend on the crack-tip velocity v and on the temperature T , and that: [7]

$$G(v, T) = G_0[1 + f(v, T)] \quad (1)$$

Where: $f \rightarrow 0$ as $v \rightarrow 0$. Thus, G_0 is a threshold value below which no fracture occurs.

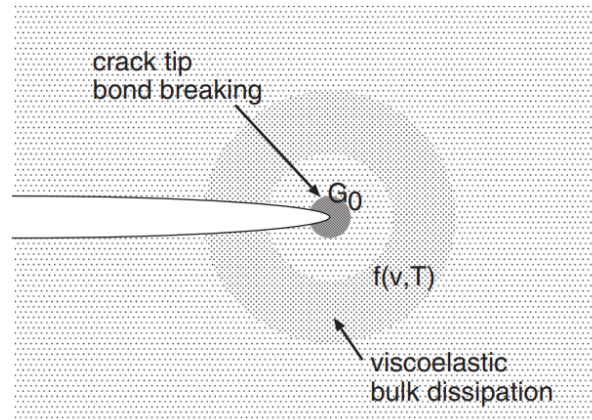

Figure 18: The crack propagation energy G is a product of a term G_0 derived from the bond breaking at the crack tip, and a term $f(v, T)$ derived from the bulk viscoelastic energy dissipation in front of the tip. [7]

Since rubbers are not ideally elastic but are capable of hysteresis, conversion of mechanical energy to thermal. It was necessary to adjust Griffith's theory. In 1953, it was modified by Rivlin and Thomas. Due to hysteresis, energy loss has to be taken into account, and Therefore critical tearing energy has been established. [30]

3.3.1.1 Energy required to grow a crack

Close to the sharp of the crack elastic strain of energy decreases, but there is no increase in free energy cracked body but converting of energy to heat, which leads to irreversible deformation. The area where these changes are taking place is very small compared to body dimensions. Rivlin predict that the energy required for crack growth does not depend on the size and geometry of the test specimen. Thus, the energy needed to increase the cracks per unit area was defined. [30]

$$T = -\frac{1}{t} \left(\frac{\partial U_{el}}{\partial a} \right)_t \quad (2)$$

Where:

T – tearing energy

U_{el} - elastic strain energy stored in the body

a - crack length

t - thickness of test sample

Experimental measurement concluded that if the crack propagation is expressed by energy, we can neglect the size and geometry of the sample.

Rivlin and Thomas described the tearing energy dependence on the diameter of the sharp crack. [30]

$$T \cong W_b \cdot d \quad (3)$$

Where:

T – tearing energy

W_b - work required to break a unit volume of material

d - average of crack sharp

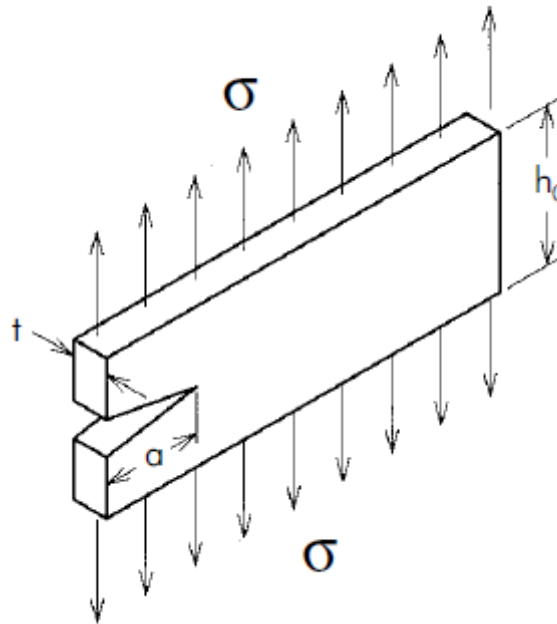

Figure 19: Scheme of Pure-shear specimen

For experimental determination of tearing energy, was used Pure-Shear specimen (Figure 19). The SENT test specimen can be also used. The test specimen SENT is shaped as a strip with notch on one side. It is important that the crack length is small compared to the width of sample and the tip of the crack is far enough from the free edge opposite the crack. [38]

3.3.2 Fatigue during dynamic loading

For the description of fatigue during dynamic loading is important the relationship between the growth rate of the da/dn cracks and the tearing energy T . This dependence is characterized by the crack growth rate and was derived by Gent, Lindley and Thomas. Figure 5 shows the dependence of the crack growth rate on the tearing energy that Lake & Lindley divided into four parts. Each part characterizes the material in other value tearing energies. [21,31]

Description of parts of the graph on the figure 5:

- I. – For tearing energy values, less than T_0 , the crack grows at a constant rate. Crack growth is not dependent on dynamic loading, but is influenced by the environmental attack.

$$T \leq T_0 \rightarrow \frac{da}{dn} = r \quad (4)$$

- II. – Transition between a nucleation and propagation of crack growth ($T_0 - T_1$):

$$T_0 \leq T \leq T_1 \rightarrow \frac{da}{dn} = A(T - T_0) + r \quad (5)$$

- III. – In this part, crack growth is stable ($T_1 - T_c$). The relationship between fatigue crack growth rate da/dn and tearing energy is described by Paris & Erdogan with the power-law:

$$T_1 \leq T \leq T_c \rightarrow \frac{da}{dn} = b \cdot \Delta T^m \quad (6)$$

where b and m are material constants.

- IV. In the last region, IV, the tearing energy T_c proceeds to the unstable state of crack growth and the crack growth rate will become essentially infinite. [19]

$$T \approx T_c \rightarrow \frac{da}{dn} = \infty \quad (7)$$

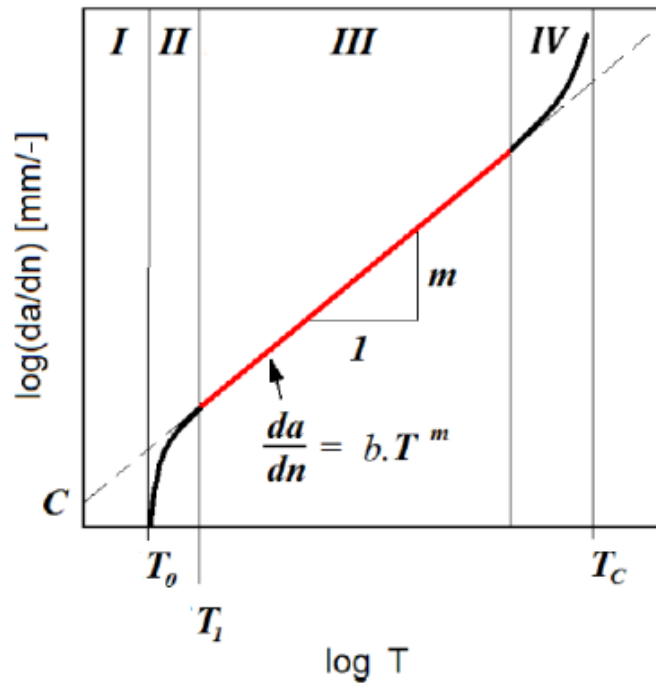

Figure 20: Dependence of crack grow rate on tearing energy [21]

3.3.3 Description of mechanical loading

Simple mechanical loading can be described by various parameters. For example: maximum, alternate, minimum and average load and / or ratio R. For characterize of mechanical loading can use parameter P(t). Parameter P can be described by: [32]

$$P(t) = P_a \sin(\omega t) + P_m \tag{8}$$

Where:

P_a – alternating load

P_m – mean load

Parameter P can also describe the maximum (P_{max}) and minimum loading (P_{min}):

$$P(t) = P_{max} \frac{1 + \sin(\omega t)}{2} + P_{min} \frac{1 - \sin(\omega t)}{2} \tag{9}$$

Using the R-ratio, parameter P will be described by the equation: [20]

$$P(t) = \frac{P_{max}}{2} [1 + \sin(\omega t) + R(1 - \sin(\omega t))] \tag{10}$$

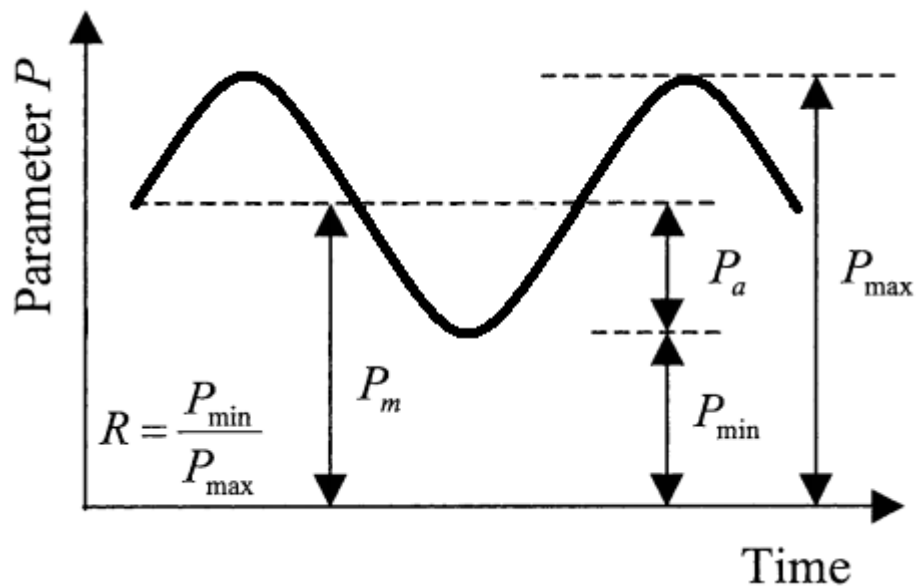

Figure 21: Parameter P [32]

3.4 Fatigue of EPDM

As already mentioned, there are many factors that influence the fatigue process of rubbers. For EPDM, only a very small amount of these process was experimentally described, research in this area focused mainly on natural rubber, SBR and NBR, but EPDM is becoming more and more of interest to researchers.

3.4.1 Effect of mechanical loading

The influence of mechanical loading in his publications is described by Abraham et al. [33,34]. The results is that the fatigue properties of EPDM strongly depend on the used amplitude and the minimal stress. This dependence applies to EPDM at the same loading of carbon black at the same temperature and frequency. Furthermore, it has been found that despite the increase in the minimum stress at the same amplitude, the service life could be increased. This service life increase is attributed to the characteristics of the filled system.

3.4.2 Effect of carbon black loading

The effect of carbon black in his publications is described by Stoček el al [35]. It has been shown that the carbon black concentration in EPDM has an effect on the rate of crack growth. Increasing the concentration of carbon black results in lower crack growth rates at the same tearing energy.

Furthermore, the minimum energy required for crack growth was also monitored. The dominant influence of carbon black particles was determined. The effects for N330 and N550 were monitored. The minimum energy required for crack growth was for the N330 filled EPDM higher than for the EPDM filled with N 550. The concentration of fillings performance was monitored for minimal energy, EPDM with a lower concentration of carbon black required higher energy for crack growth.

II. ANALYSIS

4 PREPARATION OF SAMPLES

4.1 Rubber compound recipes

Four compounds were proposed (Table 1). All based on EPDM rubber. Two types of EPDM rubber were used. Carbon black with content 60 phr and 55 phr was used as a filler. The compound with 60 phr of carbon black also contained oil and more lubricant. Two types of peroxide vulcanization systems were used as well.

The mixture designations were chosen as A6, A5, B6 and B5. Where the letters A and B indicate the type of rubber used and the numeral indicate content of carbon blacks.

Recipes were designed in collaboration with Datwyler Sealing Technologies CZ s.r.o. The formula can only be published in general, however precise formulas of the compounds were known.

Tab. 1: Recipe of compounds in phr

	A6	B6	A5	B5
EPDM A	100.00	----	100.00	----
EPDM B	----	100.00	----	100.00
CARBON BLACK N 550	60.00	60.00	55.00	55.00
OIL	5.00	5.00	----	----
LUBRICANT	3.00	3.00	0.50	0.50
ZINKOXIDE AKTIV				
ANTIOXIDANTS				
STEARIC ACID				
CO-AGENTS	CO-AGENT 1		CO-AGENT 2	
PEROXIDES	PEROXIDE 2		PEROXIDE 1	
SUM	176.47	177.07	165.65	166.65

The diene component in EPDM A and EPDM B is ethyldenenorbornene. EPDM A has a lower diene content and a lower ethylene content than EPDM B. Both EPDMs are low Mooney viscosity types.

4.2 Preparation of compounds

Compound was mixed in 2 steps in internal mixer according to the procedure in the Tab. 2 and Tab. 3. The total weight of the compound was 1300 g.

Tab. 2: First step of mixing

PARAMETER	TIME [s]	ENCORE	VENTILATION-TIME [s]	RPM [r/min]	TEMPERATURE [°C]
START	0	Rubber + chemicals	-	30	-
1.VENTILATION	60	-	10	25	-
2.VENTILATION	120	-	10	20	-
MIXING	240	-	-	20	max. 130
TEMPERING [°C]	T_{Body} [°C]: 50				

Tab. 3: Second step of mixing

PARAMETER	TIME [s]	ENCORE	VENTILATION-TIME [s]	RPM [r/min]	TEMPERATURE [°C]
START	0	Basic mixture + peroxides	-	15	-
1.VENTILATION	60	-	10	15	-
2.VENTILATION	120	-	10	15	-
MIXING	190	-	-	15	max. 110
TEMPERING [°C]	T_{Body} [°C]: 50				

Temperature of internal mixture was set 50 °C. Upon mixing, the temperature was ca. 86 °C. After cooling the mixed compound was rolled into the sheet on Double roll mill.

The mixed compound was rolled for 5 minutes at 16 rpm. Temperature of rolls was 50 °C and the distance between the rolls was 1,5 mm. The finally sheet thickness was ca. 3 mm.

4.3 CHARACTERIZATION OF RHEOLOGICAL PROPERTIES

Rheological properties of prepared rubber compounds were determined by rheometer MDR 3000. MDR 3000 is a rheometer containing oscillating rotor inside the chamber into which the sample of compound is placed. The principle is based on measuring the torque, which is induced by constant frequency. Dependence of torque on time expressed by vulcanization curve is gained as a result. From MDR test these parameters were determined: scorch safety (T_2), cure time (T_{90}), maximal torque (S_{min}) and minimal torque (S_{max}). The test was carried out at 175 °C.

Tab. 4: Rheological parameters of prepared rubber compounds for 175 °C

	T₂ [min]	T₉₀ [min]	S_{MIN} [dNm]	S_{MAX} [dNm]
B5	0,61	5,18	1,82	24,97
B6	0,94	8,38	1,85	19,13
A5	0,72	5,42	1,79	23,18
A6	0,87	8,21	1,85	22,62

The measurement results of rheological properties show that the lowest scorch safety was B5 and highest B6. The time T₉₀ is higher for compound with higher loading of carbon black by approx. 3 minutes.

4.4 Preparation of testing specimens

Specimens were prepared by pressing in the LabEcon 300 hydraulic press. The specimens were plate-shaped with dimensions of 12,5 x 12,5 x 0,2 / 0,1 cm and Pure-shear specimens. The plates-shaped specimen was subsequently used for the preparation of the specimens by cutting. Test specimens were prepared in the molds of the required geometry. The pressure was 200 kN, the same temperature was used as for measuring the vulcanization curve at 175 ° C. The time of vulcanization was determined from time T₉₀ (Table 4) and one minute was added to each millimeter of thickness. Testing specimen geometry and dimensions will be given in test descriptions.

5 EXPERIMENTAL METHODS

5.1 Basic material characterization

5.1.1 Hardness test

The test was performed according to the standard ČSN ISO 7619-1. Device was used Hardness tester Shore A. Test specimen is formed by three layers of plate with dimension 12,5 x 12,5 x 0,2 mm. The test was performed for 1 specimens from each compound. Five measurements are made for each specimen.

The principle of Shore's method is to measure the depth of a specified tip embedded in a material sample under specified conditions. The depth of the pressed tip is inversely proportional to the hardness value.

5.1.2 Tensile test

The test was performed according to the standard ČSN ISO 37. Device which was used was Testometric M350-5CT. A dumbbell-shaped specimen (ISO 37- TYPE 2) was used. The test was performed for five specimens from each compound. The test was performed without a strain gauge, as it was not available. Extension stress values were subtracted from clamp position.

The principle of the tension test is deformed in tension to the test body of a known cross-section at a known speed and detecting stress at the known deformation. Tests were performed at 200 mm / min.

5.2 Advanced material characterization

5.2.1 Intrinsic Strength Analyzer

Intrinsic strength Analyzer – ISA© (Coesfeld GmbH, Germany) was used to determine intrinsic strength. The mechanical principle of the intrinsic strength analyzer shown in Figure 23 used for the analyses, is illustrated in Figure 22. [35,37]

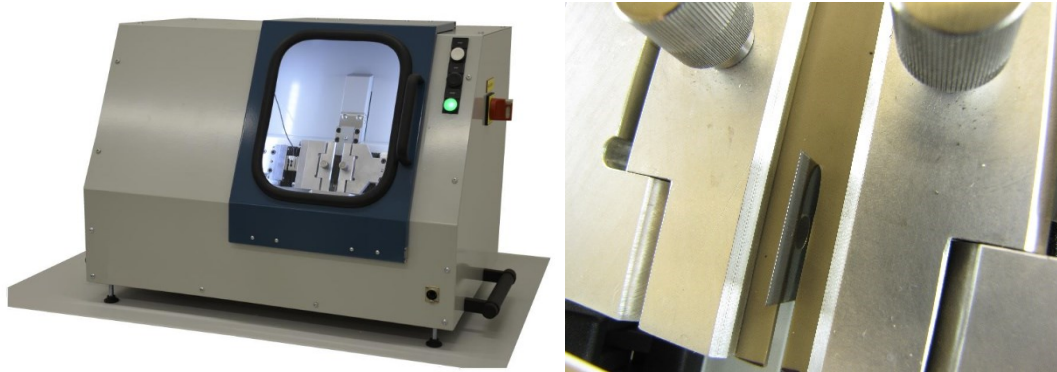

Figure 22: Intrinsic strength analyzer (ISA™) (left), Detail on the cutted test specimen during operating (right). [37]

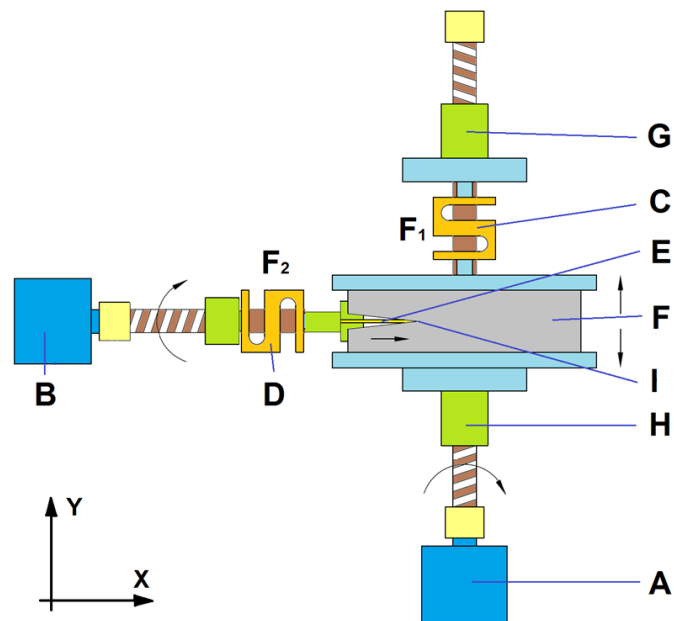

Figure 23: Measurement principle, where: A – actuator of the axis Y; B – actuator of the axis X; C – loading cell of the axis X; D – loading cell of the axis Y; E – razor blade; F – test specimen; G – upper clamping system of test specimen; H – bottom clamping system of test specimen, I – razor blade tip [37]

The test sample is clamped into a tensile measuring station, which is instrumented to measure and control force and strain in the Y-Axis. The tensile set-up is symmetrical, meaning that the center of the sample remains at initial position during variation of stress and/or strain. In this stable center axis a second actuator is positioned, which is also instrumented to measure and control force and/or strain (X-Axis). The tip of the x-axis is free and equipped with a cutting blade, which cuts through the sample at a rate (or series of rates) that is specified by the experimental protocol. The measurement of the intrinsic strength is performed in the pure-shear region of the test specimen determined in Stoček et al.[37].

Measurement of intrinsic strength consists of several steps. In the first step, a pre-crack with necessary length was created, so that the crack tip was in the pure-shear region. Then, deformation is then applied and fixed (Y-Axis) and the sample is left for 5 minutes to relax, at all times, the force on the Y-axis was measured. After the relaxation follows the cutting sequence for all three rates of blade, in this order of 10 mm / min, 0.1 mm / min and 0.01 mm / min. In this step, force for both axis was measured. [37]

The result of the analysis is the determination of intrinsic cutting energy. When measuring on a test sample, we apply two deformations, namely the tearing energy, which is defined by the relationship:

$$T = W \cdot h \quad (11)$$

Where:

T – Tearing energy

W – the strain energy density

h – cross-section of specimen

The second deformation we perform on the sample is caused by a razor blade. At constant blade rate, the cutting force is given by the relationship:

$$F = \frac{f}{t} \quad (12)$$

Where:

F – Cutting energy

f – The cutting force

t – thickness of specimen

and the resulting energy the intrinsic cutting energy is given by the relationship:

$$S_c = T + F \quad (13)$$

Where:

S_c – Intrinsic cutting energy

The intrinsic strength T_0 (endurance limit) is proportional to $S_{0,c}$, with a proportionality constant, b that is a function of the blade sharpness:

$$T_0 = b * S_{0,c} \quad (14)$$

The proportionality constant, b can be evaluated by the testing of a calibration material in the Intrinsic Strength Analyzer. [37]

5.2.1.1 *Boundary conditions of analysis*

The boundary conditions of the analysis are shown in Table 5. Measurement was performed for 13. Deformation ranging from 0,01% to 0,5%. The rate of blade was 10, 0,1 and 0,01 mm/ min, which was applied sequentially. Pure-shear specimen (Figure 24) was used.

Tab. 5: Measurement parameters

PARAMETER	VALUE
DEFORMATION [%]	0,01 – 0,5
RATE OF BLADE [mm/ min]	10; 0,1; 0,01

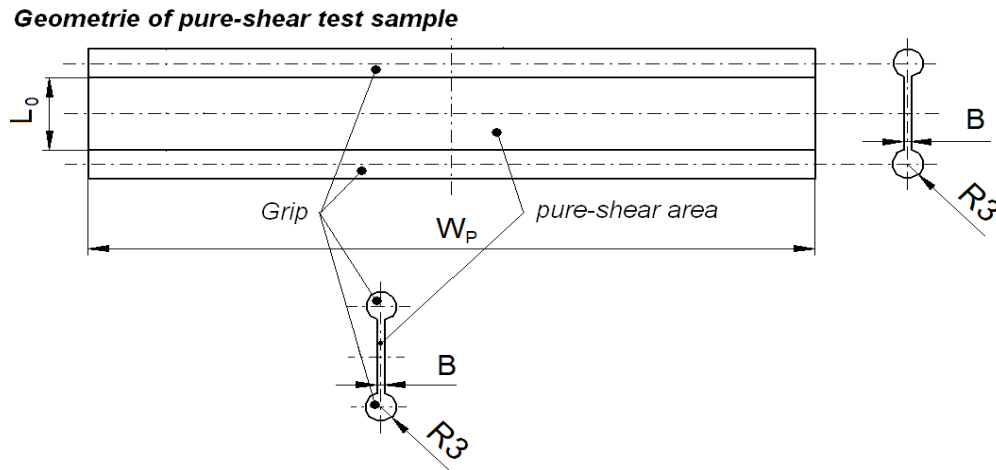

Figure 24: Sample with a fixing shoulder of the following dimensions: $L_0 = 4$ mm, $W_p = 40$ mm, $B =$ from 0,5 up to 2 mm, $R = 3$ mm. [35]

5.2.2 Tear and fatigue analyzer

Fatigue crack growth analysis and intrinsic strength analysis were used to describe the fatigue behavior of rubber. The intrinsic strength of the material and the dependence of the crack growth rate on the tearing energy were determined.

Tear and Fatigue Analyzer was used to describe propagation and determination crack growth resistance. The SENT, pure-shear, dumbbell hantel specimens can be used.

A Tear and Fatigue Analyzer (coesfeld GmbH, Germany) was used to determine fatigue crack growth as shown in Figure 5. A detailed description of the device can be found in Eisele et al [39]. The Tear and Fatigue Analyzer consists of three independent loading engines. Three samples can be analyzed on each engine. the device allows to apply the analysis of different loading modes (sine-, triangle-, pulse loading, free loading curve), within the frequency range 0,1 – 50 Hz. Each upper clamp attachment of test specimens is fixed to the load cell and its corresponding test specimen clamp attachment is connected to a separate computer-controlled stepping motor to ensure constant prestress during the whole time of testing. [39]



Figure 25: Tear and Fatigue Analyzer

Crack growth of each rubber test sample is monitored by a high-speed CCD image processing system mounted on a linear motion axis system. The camera moves along the xy axis from the test sample to the test specimen and takes a picture of the test specimen. Then the image is transferred to the scanning frame and saved. After digitizing the image, the software localizes in situ the crack position and determines the contour length according to the black-and-white boundary line of the crack. [39]

5.2.2.1 Boundary conditions of analysis

The boundary conditions of the analyze are shown in Table 6. The Analysis was performed at 20 °C. Measurements were made for tearing energy corresponding to 10, 30, 50 and 70% of strain.

Tab. 6: Boundary conditions

PARAMETER	VALUE
WAVE FORM	Sine
TEMPERATURE	20 °C
FREQUENCY	10 Hz
STRAIN	10, 30, 50 and 70 %
PRE-STRESS	1 N

The test was performed on Pure-shear specimen (figure 26). With the crack formed on both sides of specimen. On the one sample was followed by a crack growth for two independently cracks. Three test specimens were measured for each material and 2 cracks were evaluated for each specimen.

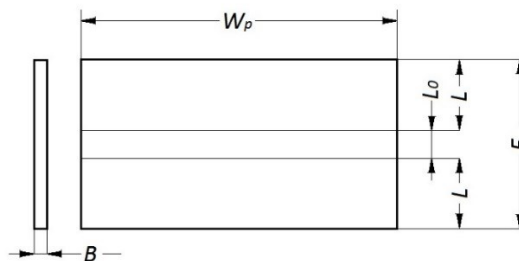

Figure 26: Simple plane sample of the following dimensions: $E = 24$ mm, $W_p = 40$ mm, $B = 1$ mm.

The test was performed with sine load (Figure 27) and a frequency of 10 Hz and pre-stress of 1 N.

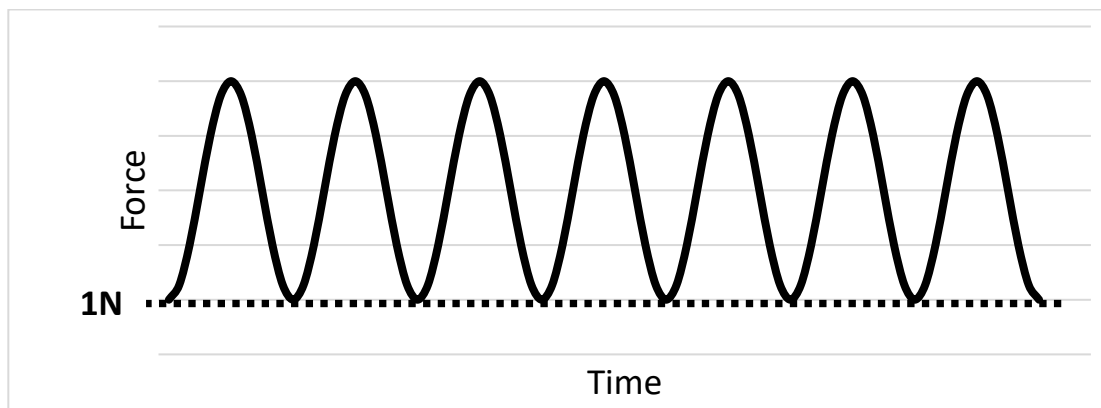

Figure 27: Scheme of mechanical loading

6 RESULTS AND DISCUSSION

For the characterization of compounds, the following tests were performed: Hardness test, Tensile test, Intrinsic strength analysis and Fatigue crack growth analysis.

6.1 Hardness test

For the basic characterization of the compounds, the hardness test described in Chapter 5.1 was used. The results are shown in Table 7.

Tab. 7: Results of Hardness test

	1	2	3	4	5	MEDIAN
A5	72	72	71	71	71	71
A6	71	71	71	71	71	71
B5	73	73	73	73	73	73
B6	71	70	71	71	71	71

The hardness was the same for A5, A6 and B6 materials, and was 71 Shore A. Material B6 showed a higher value of 73 Shore A. Despite the higher hardness of B, we can say that all blends are similar and do not show any greater differences.

6.2 Tensile test

A Tensile test was then carried out as described in Chapter 5.2. The results are shown in Table 8.

Tab. 8: Results of tensile test

	A5	A6	B5	B6
M50 [MPa]	1.26 ± 0.03	1.30 ± 0.04	1.43 ± 0.04	1.20 ± 0.01
M100 [MPa]	2.18 ± 0.03	2.3 ± 0.1	2.44 ± 0.12	1.92 ± 0.06
M300 [MPa]	7.1 ± 0.30	7.1 ± 0.2	7.19 ± 0.18	5.55 ± 0.17
STRESS AT BREAK [MPa]	12.9 ± 0.70	14.1 ± 0.7	14.40 ± 0.50	13.7 ± 0.5
STRAIN AT BREAK [%]	526.00 ± 9.00	590 ± 30	599 ± 19	720 ± 30

The values from Table 8 were plotted (Figure 28) and graph were constructed.

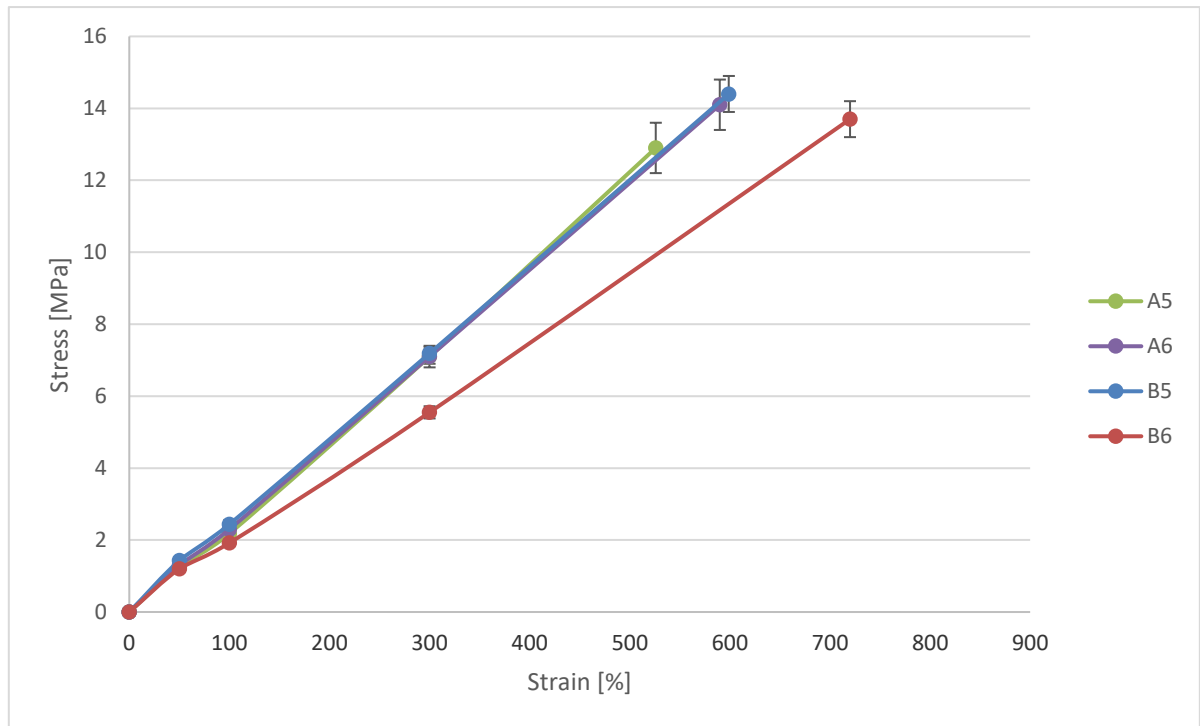

Figure 28: Tensile test - modulus

From the tensile curve and the results shown in Table 8, it can be seen that in the case of low deformations (M50), the materials behave similarly, the stress differences being within the range of 0.2 MPa. Deformation of the M100 already shows higher stress differences. At higher loads (M100) there is a stress increase that is still in the range of 0.2 MPa for A5, A6 and B5, but B6 has lower stress. With the application of an even higher stress (M300, stress at break), we can observe the still greater differences between the tensile properties of B6 and the remaining three compounds with no such differences. In the tensile test results, we can see mainly large differences of B6 material at deformations higher than M100 compared to other materials. Material B6 is softer and more elastic.

6.3 Intrinsic Strength Analysis

To characterize the fatigue behavior of materials at very low deformations, an intrinsic strength analysis was used, which was presented in Chapter 5.3. The results are shown in Figure 29 and Figure 30.

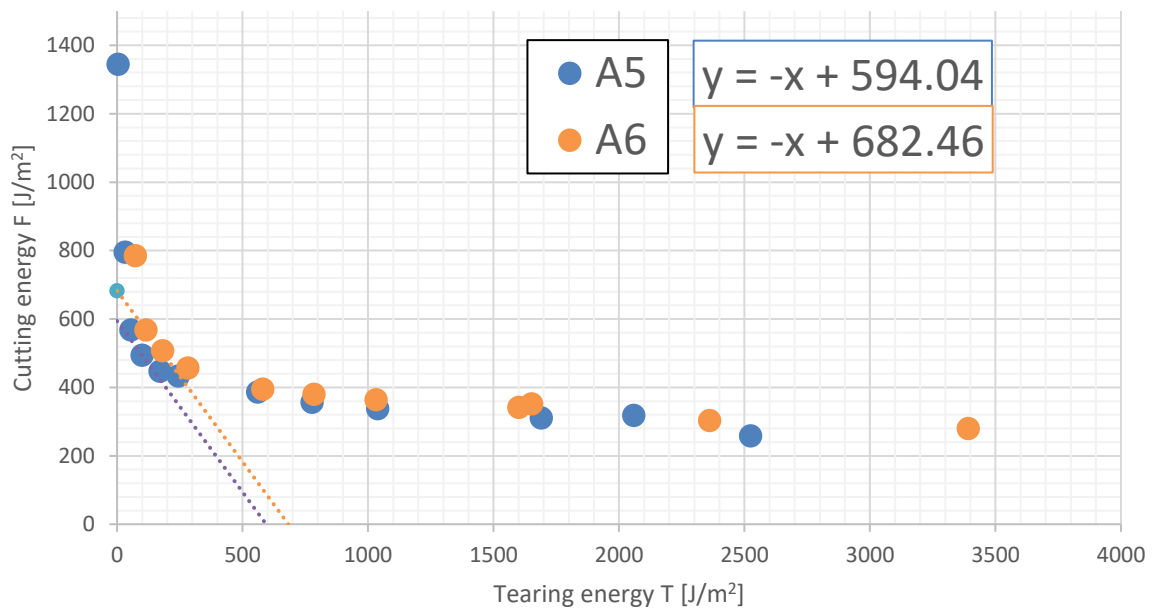

Figure 29: Dependence of cutting energy vs tearing energy for A5, A6

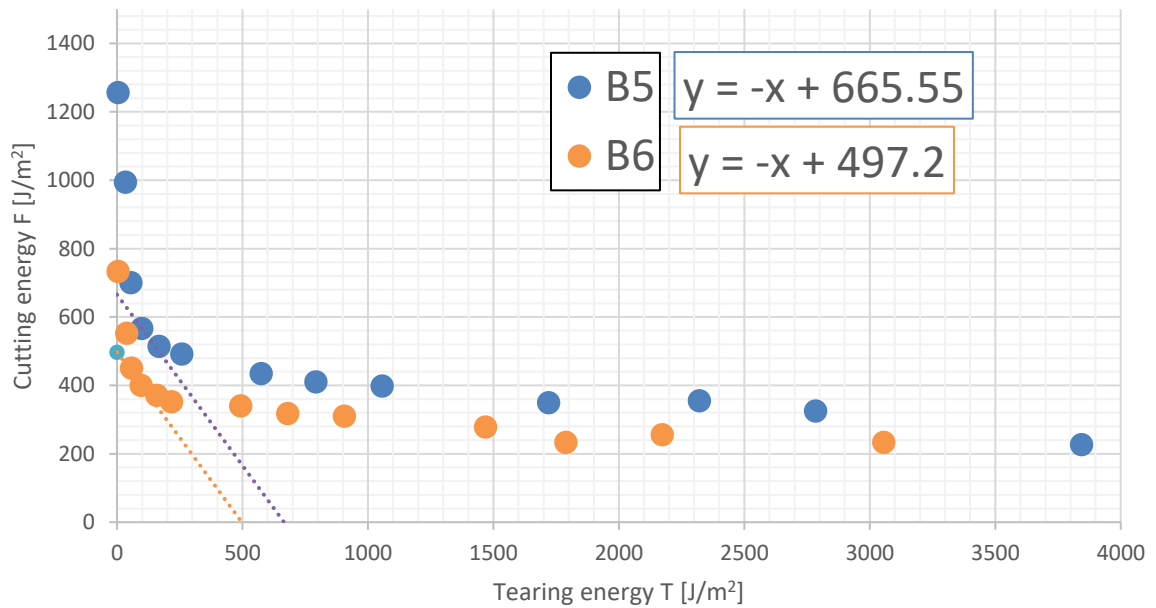

Figure 30: Dependence of cutting energy vs tearing energy for B5, B6

The lowest intrinsic cutting energy is clearly observed for B6, $Sc = 497.2 \text{ J/m}^2$. The highest intrinsic cutting energy observed was for A6, $Sc = 682.46 \text{ J/m}^2$. The value of intrinsic cutting energy for material A6 is very close to material B5, $Sc = 665.55 \text{ J/m}^2$. Material A5 was $Sc = 594.04 \text{ J/m}^2$.

When analyzing the internal strength, the intrinsic cutting energy value, which is higher than the actual internal strength, was measured. The actual value of intrinsic strength can be determined very simply because the intrinsic cutting energy value Sc and intrinsic strength between

us is a linear dependence, but measurement of the reference materials is required, thus the final endurance limit has the same ranking for the analyzed materials. The endurance limit respective intrinsic strength value will be approximately 10 time lower than the values of intrinsic cutting energies.

By comparing measured intrinsic cutting energy values with SBR rubber, which typically has values around $Sc = 100 \text{ J/m}^2$, double the EPDM.

The conclusion of this analysis is that for the low deformation application, the A6 material is the best choice.

6.4 Fatigue crack growth analysis

For characterization of fatigue behavior at the region of stable growth of crack, fatigue crack growth analysis was used, as described in Chapter 5.4.

Crack growth rate was measured for tearing energy $T = 150, 300, 500$ and 700 J/m^2 .

Fatigue behavior at the region of stable growth of crack for A5 is described in Figure 31. The exponent m shows the value $m = 3.79$. The average crack growth rate of tearing energy 150 J/m^2 is $1.48 \times 10^{-7} \text{ mm/cycles}$. For a tearing energy of 300 J/m^2 , the crack growth rate is $2.07 \times 10^{-6} \text{ mm/cycles}$. For tearing energy of 500 J/m^2 , the crack growth rate is $1.44 \times 10^{-5} \text{ mm/cycles}$ and for a tearing energy of 700 J/m^2 the crack growth rate is $5.27 \times 10^{-5} \text{ mm/cycles}$. With tearing energies of $150\text{-}500 \text{ J/m}^2$, we can observe increase a order of magnitude in crack growth rate with the tearing energy. When comparing the crack growth rate at tearing energies of 500 and 700 J/m^2 , we can see a slowdown of the rate of crack growth.

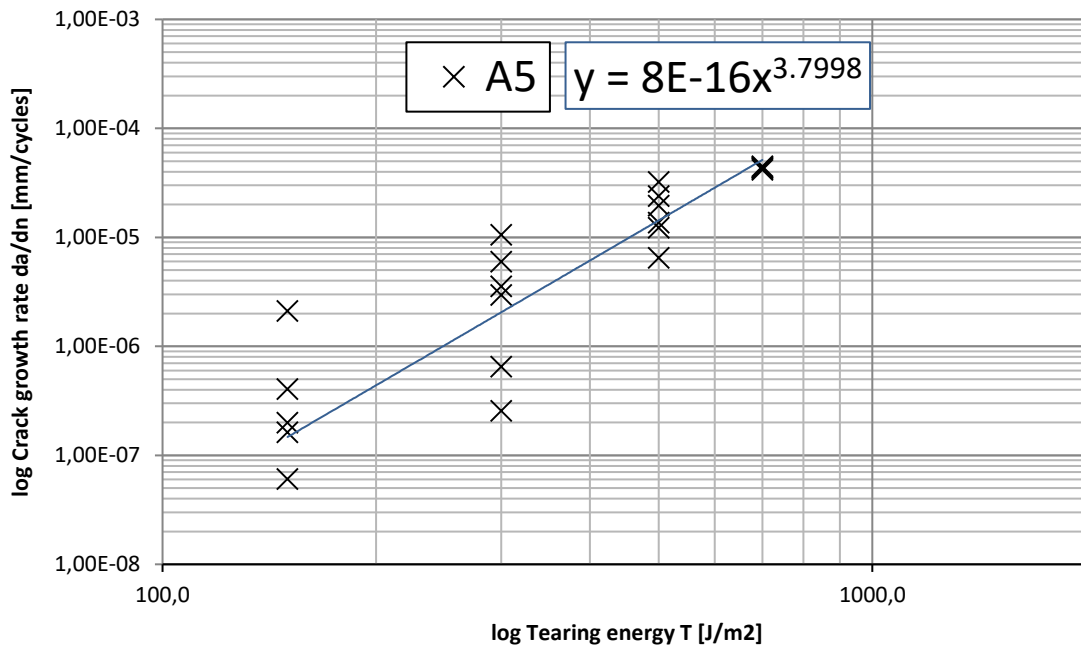

Figure 31: Dependence of Crack growth rate vs. Tearing energy for A5

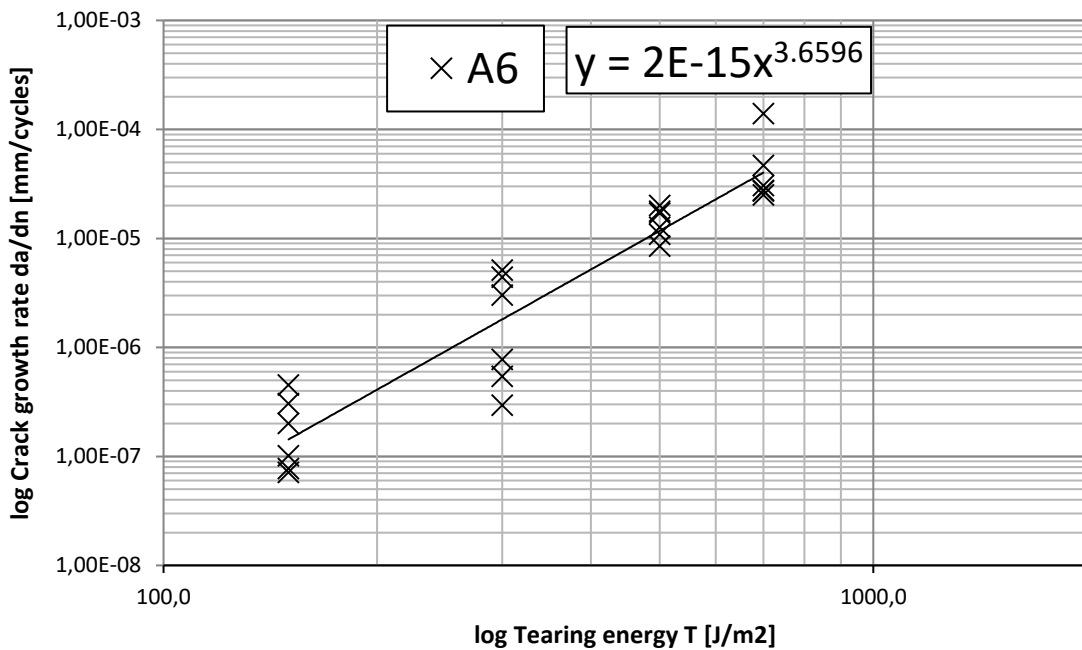

Figure 32: Dependence of Crack growth rate vs. Tearing energy for A6

Fatigue behavior at the region of stable growth of crack for A6 is described in Figure 32. The exponent m shows the value $m = 3.65$. The average crack growth rate of tearing energy $150 J/m^2$ is 1.83×10^{-7} mm/cycles. For a tearing energy of $300 J/m^2$, the crack growth rate is 2.32×10^{-6} mm/cycles. For tearing energy of $500 J/m^2$, the crack growth rate is 1.51×10^{-5} mm/cycles and for a tearing energy of $700 J/m^2$ the crack growth rate is

5.16×10^{-5} mm/cycles. With tearing energies of 150-500 J/m², we can observe same tendency of increase of crack growth rate with the tearing energy and the same tendency of deceleration of the crack growth rate at tearing energy 700 J/m² as for material A5.

By comparing the behavior of A5 and A6 materials at region of stable growth of crack, it can be concluded that A6 is more resistant to crack growth.

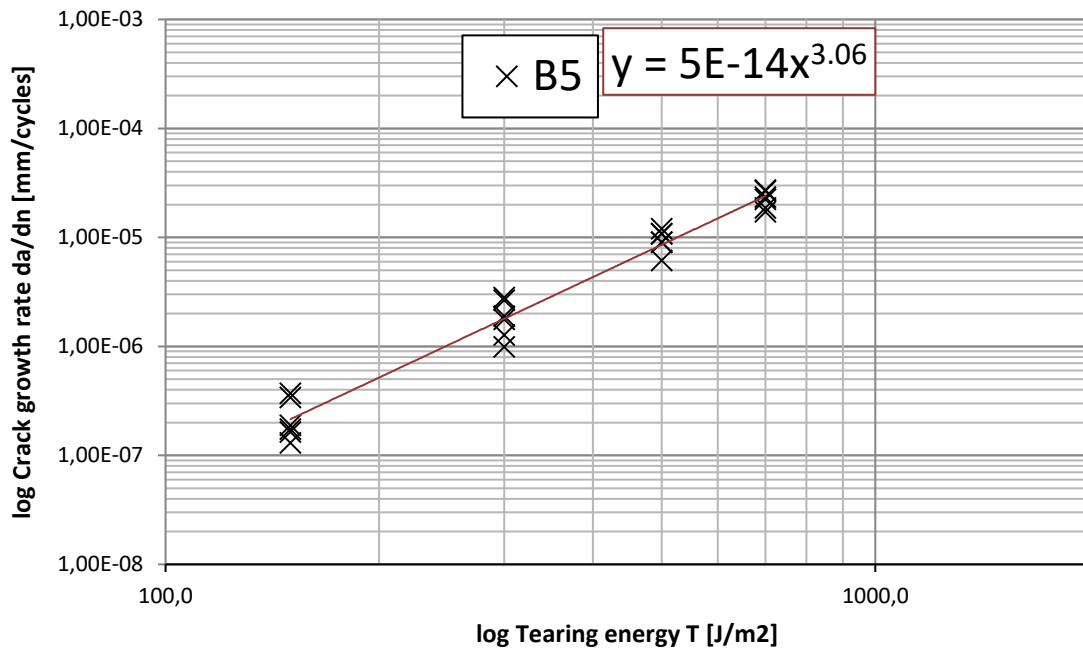

Figure 33: Dependence of Crack growth rate vs. Tearing energy for B5

Fatigue behavior at the region of stable growth of crack for B5 is described in Figure 33. The exponent m shows the value $m = 3,06$. The average crack growth rate of tearing energy 150 J/m² is 2.28×10^{-7} mm/cycles. For a tearing energy of 300 J/m², the crack growth rate is 1.9×10^{-6} mm/cycles. For tearing energy of 500 J/m², the crack growth rate is 9.07×10^{-6} mm/cycles and for a tearing energy of 700 J/m² the crack growth rate is 2.54×10^{-5} mm/cycles.

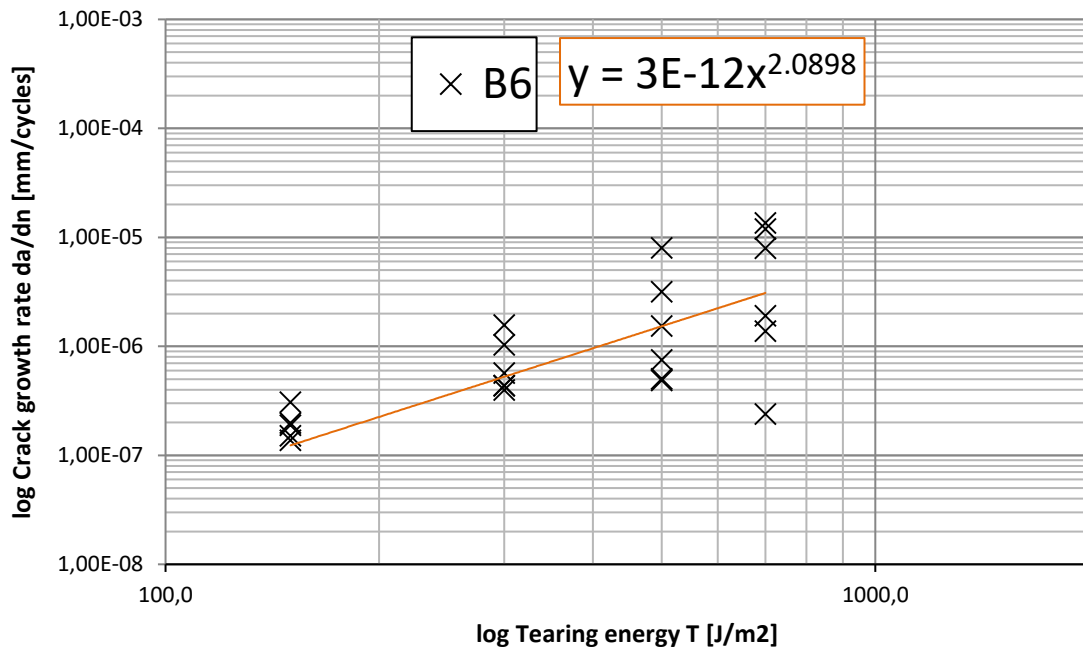

Figure 34: Dependence of Crack growth rate vs. Tearing energy for B6

Fatigue behavior at the region of stable growth of crack for B6 is described in Figure 33. The exponent m shows the value $m = 2,08$. The average crack growth rate of tearing energy $150 J/m^2$ is $1,06 \times 10^{-7}$ mm/cycles. For a tearing energy of $300 J/m^2$, the crack growth rate is $4,51 \times 10^{-7}$ mm/cycles. For tearing energy of $500 J/m^2$, the crack growth rate is $1,31 \times 10^{-6}$ mm/cycles and for a tearing energy of $700 J/m^2$ the crack growth rate is $2,65 \times 10^{-6}$ mm/cycles.

When comparing materials B5 and B6, it is clear that B6 has lower crack growth rate at the given tearing energy. Thus, it can be stated that B6 material is more resistant to crack growth than B5 material.

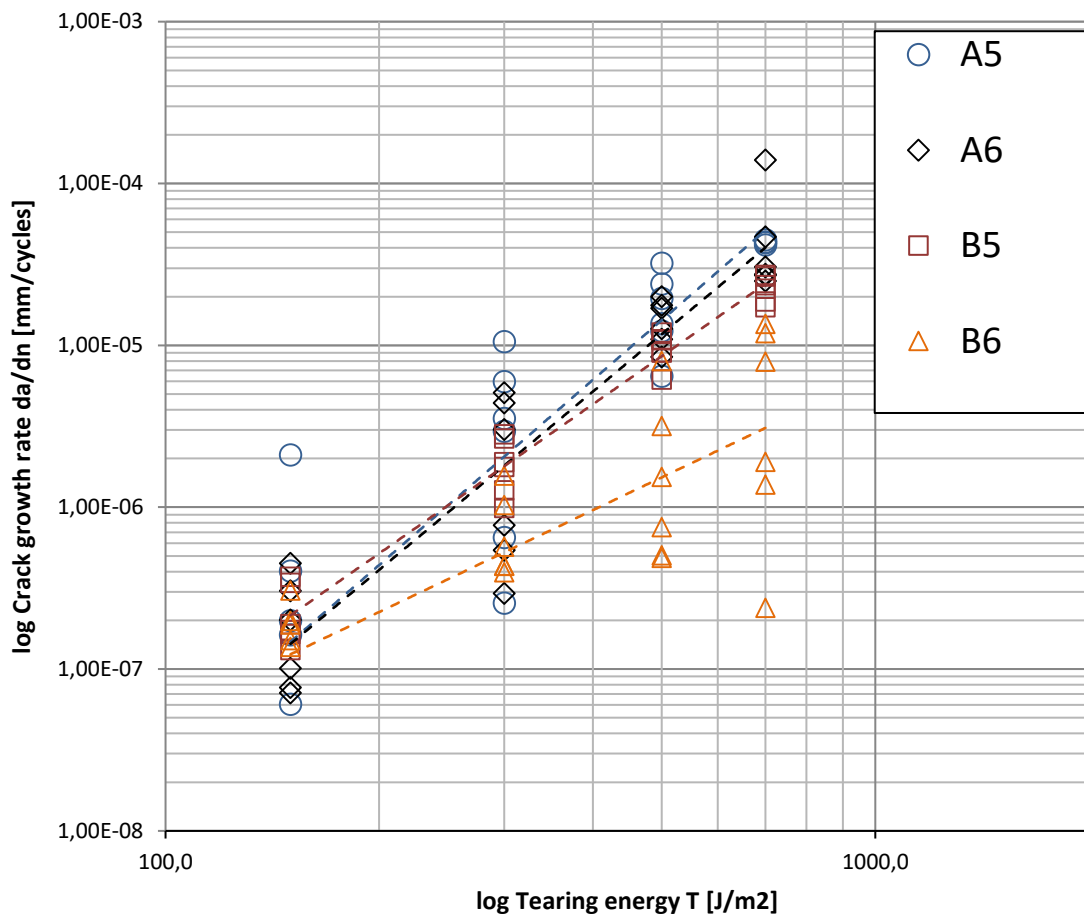

Figure 35: Dependence of Crack growth rate vs. Tearing energy for all material

Figure 35 shows all the materials. When comparing the material with a tearing energy of 150 J/m², we can state that the lowest crack growth rate is represented by material B6 and the highest by material B5. When comparing materials at a tearing energy of 300 J/m² we can see the intersection of the curves of materials A5, A6 and B5. The above-mentioned materials show a very similar crack growth rate with this tearing energy. However, B6 shows lower crack growth rate in the order of magnitude. At tearing energies of 500 and 700 J/m² we can see a higher tendency of crack growth rate for materials A5 and A6 than for B5. B6 I material still exhibits a very low crack growth rate compared to other materials.

Tab. 9: Average values of crack growth rates

	A5	A6	B5	B6
TEARING ENERGY [J/M2]	CRACK GROWTH RATE [mm/cycles]			
150	4,89E-07	2,00E-07	2,28E-07	1,64E-07
300	3,98E-06	2,35E-06	1,90E-06	7,38E-07
500	1,80E-05	1,44E-05	9,64E-06	2,40E-06
700	4,33E-05	4,93E-05	2,26E-05	6,14E-06

6.5 Importance of results for sealing applications

When choosing material for sealing applications, it is important to know how the seal will be loaded and size of deformation. This chapter is dedicated to discussing the results with regard to sealing applications.

When selecting material for applications with a deformation in the area of about 50 J/m², the choice of material A6 or B5 is recommended. As the energy required for crack growth is above the 50 J/m² threshold. The wrong choice would be material B6

However, if the seal for which material is selected, the load is 150 J/m². We can choose from all tested materials, as the differences in the rate of crack growth are not so different. However, B6 would be the most advantageous in this case

Already at load area 300 J / m². There are large differences between materials, while A5, A6 and B5 show almost the same crack growth rate. B6 exhibits the lowest crack growth rate and thus the highest fatigue lifetime of this load.

When we load the seal in an area of 500 - 700 J/m². Thus, the number of suitable materials is reduced. While B6 is still the recommended choice. Thus, materials A5 and A6 show an ever higher crack growth rate and thus a short fatigue lifetime. However, if high fatigue lifetime requirements were not imposed, it could be replaced by material B5, which does not reach the qualities of material B6, however exhibits a lower crack growth rate than A5 and A6

Finally, the A5 and A6 materials behave in the same way without bigger differences with increasing tearing energy. When selecting materials for low deformation, A6 or B5 is a suitable choice. Choosing material for high deformation the B6 material would be the recommended choice

CONCLUSION

This thesis deals with problems of sealing applications connected with fatigue of materials and prediction of the service life of their application. In the theoretical part, the material requirements for rubber, such as elasticity, temperature resistance, chemical resistance, resistance to permanent deformation, resistance to crack growth followed by fatigue crack growth are discussed. With regard to the material requirements, the rubber compound and its components were introduced. In the theoretical part, emphasis was placed on describing the mechanics of fatigue of rubber materials from the initiation of fatigue cracks to its growth.

The mechanism of fatigue crack initiation is not fully described, but from the point of view of the fracture mechanics, the only interruption of the bond is considered to be a defect and therefore a micro-crack - the initiation of a crack. The mechanism of crack propagation is described by Rivlin and Thomas. The growth of the crack in the area of stable growth is described by the power-law, which was derived by Paris and Erdogan.

For the experimental description of the fatigue behavior of rubber we used the most modern methods such as intrinsic strength analysis and fatigue crack growth analysis. Intrinsic strength analysis was used to determine the minimum energy required for crack growth. Fatigue crack growth analysis has been used to describe the growth of cracks in the crack growth stable region described by power-law.

In the experimental part, four EPDM-based materials, which were assembled according to the requirements of the sealing application.

Analysis of fatigue behavior of rubber materials reveals large differences between studied materials. Where a material which, at very low deformations at the crack initiation level, exhibits great resistance to initiation and growth of the crack. It exhibits a high crack growth rate at higher deformations, resulting in a low fatigue life.

In order to select the optimal material, we must know the conditions under which the seal will be exposed (load size). Consequently, we can perform analysis that characterize material behavior under these conditions. From this knowledge we can determine the fatigue life or modify the material to prolong the fatigue life. Since sealing failure can cause not only financial damage, it can also be dangerous for machine operators.

BIBLIOGRAPHY

- [1] Flitney, R. Seals and Sealing Handbook. Butterworth-Heinemann, 2014.
- [2] EPDM 70 O-Rings BS425 to BS475 | Eastern Seals (UK) Ltd. [online]. Copyright © Copyright [cit. 14.05.2018]. Available from: <http://www.easternseals.co.uk/shop/epdm-70-o-rings-bs425-to-bs475/>
- [3] Rubber Gasket - Rubber Gasket. Home [online]. Available from: <http://www.bahou-rubber.com/index.php/products/2014-05-20-17-50-37>
- [4] EPDM rubber PVC clip sheet seal strip, rubber edge trim, pvc edge seal strip, rubber sealing strip. rubber seal strip, self adhesive foam strip, epdm sponge seal strip, epdm self-adhesive rubber seal strip [online]. Copyright © China Excellent Source Co., Limited [cit. 14.05.2018]. Available from: <http://www.rubber-sealstrip.com/EPDM-rubber-PVC-clip-sheet-seal-strip.html>
- [5] Image Library: Dätwyler Holding AG. [online]. Copyright ©2018 [cit. 14.05.2018]. Available from: <https://www.datwyler.com/en/media/image-library/>
- [6] AGCO Automotive Repair Service - Baton Rouge, LA - Detailed Auto Topics - Vacuum Brake Boosters. AGCO Automotive Repair Service - Baton Rouge, LA - AGCO Automotive [online]. Copyright ©2018 [cit. 14.05.2018]. Available from: http://www.agcoauto.com/content/news/p2_articleid/129
- [7] Persson, Bo & Albohr, O & Heinrich, G & Ueba, H. (2005). Crack propagation in rubber-like materials. Journal of Physics: Condensed Matter. 17. R1071. 10.1088/0953-8984/17/44/R01.
- [8] Ozone cracking - Wikipedia. [online]. Available from: https://en.wikipedia.org/wiki/Ozone_cracking
- [9] MALÁČ, J. Gumárenská technologie I. Zlín: Tomas Bata University in Zlin, 2005.
- [10] DUCHÁČEK, V. a HRDLIČKA Z. Gumárenské suroviny a jejich zpracování. Vyd. 4., přeprac. Praha: Vysoká škola chemicko-technologická v Praze, 2009. ISBN 978-80-7080-713-2.
- [11] DUCHÁČEK, V. Polymery: výroba, vlastnosti, zpracování, použití. Vyd. 2., přeprac. Praha: Vydavatelství VŠCHT, 2006. ISBN 80-7080-617-6.

- [12] Nitrile rubber. Academic Dictionaries and Encyclopedias [online]. Copyright © Academic, 2000 [cit. 15.05.2018]. Available from: <http://enacademic.com/dic.nsf/en-wiki/1340987>
- [13] Lectures of rubber technology, Čermák R. 2017, Tomas Bata University in Zlin Faculty of Technology.
- [14] Polychloroprene. CROW [online]. Copyright © 2015 polymerdatabase.com [cit. 15.05.2018]. Available from: <http://polymerdatabase.com/Elastomers/Chloroprene.html>
- [15] Ultra-High MW EPDM as a Replacement for NR - Coi Rubber Products. Custom Rubber Manufacturer - Coi Rubber Products [online]. Copyright © 2013 Coi Rubber Products, Inc. 19255 San Jose Avenue Unit D [cit. 15.05.2018]. Available from: <https://www.coirubber.com/ultra-high-mw-epdm-replacement-nr/>
- [16] What is Carbon Black? – Monolith. Monolith [online]. Available from: <http://monolith-materials.com/innovative-technology/what-is-carbon-black/>
- [17] Julie Diani, Bruno Fayolle, Pierre Gilormini. A review on the Mullins effect. European Polymer Journal, Elsevier, 2009, pp.601-612.
- [18] Rubbers - Some aspects of rubber chemical changes.[online]. Available from: https://www.tut.fi/ms/muo/vert/5_rubber_chemistry/2_vulcanization_stages.htm
- [19] Gent, A. N. Engineering with rubber: how to design rubber components. 3rd ed. Cincinnati: Hanser Publishers, c2012. ISBN 1569905088.
- [20] Judson, T. Bauman. Fatigue, stress and strain of rubber components a guide for design engineers. München: Hanser, 2008. ISBN 9783446433403.
- [21] Lake, G. J., & Lindley, P. B. (1965). The mechanical fatigue limit for rubber. Journal of Applied Polymer Science, 9(4), 1233-1251.
- [22] Lake, G. J., & Thomas, A. G. (1967). The strength of highly elastic materials. Proceedings of the Royal Society of London. Series A. Mathematical and Physical Sciences, 300(1460), 108-119.
- [23] Lake, G. J. (1972). Mechanical fatigue of rubber. Rubber Chemistry and Technology, 45(1), 309-328.
- [24] Erman, B., Mark, J. E., & Roland, C. M. (2013). The science and technology of rubber. Amsterdam: Elsevier Academic Press.

- [25] Gent A.N. & Schultz J. (2006) Effect of Wetting Liquids on the Strength of Adhesion of Viscoelastic Material, *The Journal of Adhesion*, 3:4, 281-294, DOI: 10.1080/00218467208072199
- [26] Maugis, D., and M. Barquins. "Fracture mechanics and the adherence of viscoelastic bodies." *Journal of Physics D: Applied Physics* 11.14 (1978): 1989.
- [27] Gent, A. N. "Adhesion and strength of viscoelastic solids. Is there a relationship between adhesion and bulk properties?." *Langmuir* 12.19 (1996): 4492-4496.
- [28] Schapery, R. A. "On the mechanics of crack closing and bonding in linear viscoelastic media." *International Journal of Fracture* 39.1-3 (1989): 163-189. [9] Greenwood J A and Johnson K L 1981 *Phil. Mag. A* 43 697
- [29] Baney, J. M., and C-Y. Hui. "Viscoelastic crack healing and adhesion." *Journal of applied physics* 86.8 (1999): 4232-4241. [13] Persson B N J and Brener E 2005 *Phys. Rev. E* 71 036123
- [30] Gdoutos, E. E., I. M. Daniel, and P. Schubel. "Fracture mechanics of rubber." *Facta universitatis-series: Mechanics, Automatic Control and Robotics* 3.13 (2003): 497-510.
- [31] Stoček, R., Heinrich, G., Gehde, M., & Kipscholl, R. (2013). Analysis of Dynamic Crack Propagation in Elastomers by Simultaneous Tensile- and Pure-Shear-Mode Testing. *Fracture Mechanics and Statistical Mechanics of Reinforced Elastomeric Blends Lecture Notes in Applied and Computational Mechanics*, 269-301. doi:10.1007/978-3-642-37910-9_7
- [32] Mars, W. V., & Fatemi, A. (2004). Factors that Affect the Fatigue Life of Rubber: A Literature Survey. *Rubber Chemistry and Technology*, 77(3), 391-412. doi:10.5254/1.3547831
- [33] Alshuth, T., Abraham, F., & Jerrams, S. (2002). Parameter Dependence and Prediction of Fatigue Properties of Elastomer Products. *Rubber Chemistry and Technology*, 75(4), 635-642. doi:10.5254/1.3544990
- [34] Abraham, F., T. Alshuth, and S. Jerrams. "Dependence on mean stress and stress amplitude of fatigue life of EPDM elastomers." *Plastics, Rubber and Composites* 30.9 (2001): 421-425.
- [35] Stoček, R., Mars W.V., Kratina O., Machů, A., Drobilík, M., Kotula, O., Cmarová, A. (2017) The effect of carbon black loading on the intrinsic strength of rubber based on EPDM. Conference proceedings, PMA & SRC.

[36] Mark, J.E., Erman, B., Einrich, F.R., 1994, Eds., “Science and technology of rubber”, Academic Press, 2nd Edition.

[37] Mars, W.V., Stoczek, R., Kipscholl, C, October 10-13, 2016, Intrinsic strength analyzer based on the cutting method, Paper 79, Fall 190th Technical meeting of the rubber division of the American chemical society, Inc, Pittsburgh, PA, ISSN: 1547-1977

[38] Stoček, R., Heinrich, G., Gehde M. a Kipscholl, R., A New Testing Concept for Determination of Dynamic Crack Propagation in Rubber Materials. KGK - Kautschuk, Gummi, Kunststoffe. 2012, vol. 65, iss. 9, s. 49-53. ISSN 0948-3276.

[39] Eisele, U., Kelbch, S.A., Engels, H.-W, 1992, The Tear Analyzer – A New Tool for Quantitative Measurements of the Dynamic Crack Growth of Elastomers, Kautschuk-Gummi-Kunststoffe, 45, pp. 1064-1069.

LIST OF ABBREVIATIONS

ABC	First abbreviation – meaning
B	Second abbreviation – meaning
C	Third abbreviation – meaning
EPDM	Ethylene propylene diene rubber
NBR	Nitrile butadiene rubber
CR	Chloroprene rubber
FMK	Fluoroelastomers
PHR	Number of parts per hundred pieces of rubber
MDR	Moving die rheometer
G	Crack driving force
T	Tearing energy
U_{el}	Elastic strain energy stored in the body
a	Crack length
t	Thickness of test sample
W_b	Work required to break a unit volume of material
d	Average of crack sharp
SENT	Single edge notched tension
dn/da	Crack growth rate
T_0	Threshold tear energy
T_c	Critical tearing energy
P	load
P_a	alternating load
P_m	mean load
ISA	Intrinsic strength analyzer
f	The cutting force

F	Cutting energy
h	Cross-section of specimen
S_c	Intrinsic cutting energy
S_0	Intrinsic strength

LIST OF FIGURES

Figure 1: Seals; A) O-ring; B) Gasket; C) Profile-shaped seal [2,3,4]	13
Figure 2: Seals; A) Diaphragm for brake booster; B) Diaphragms; C) Caliper for Disc- Brake; D) Piston protection cap [5]	14
Figure 3: Scheme of O-ring in the groove	15
Figure 4: Scheme of function of O-ring, A) Interference force created by compression in the groove; B) Deformation of the O-ring due to compression.....	15
Figure 5: Scheme of function of O-ring at applied liquid pressure.....	15
Figure 6: Vacuum brake booster at rest (left) and in use (right) [6]	16
Figure 7: Microcrack in the crack tip (left); crack on the surface of O-ring (right) [7,8]....	17
Figure 8: Nitrile butadiene rubber [12]	20
Figure 9: Chloroprene rubber [14]	20
Figure 10: EPDM rubber [15]	22
Figure 11: Carbon black [16]	26
Figure 12: Effect of carbon black volume on compound properties and final rubber behavior [36].....	27
Figure 13: Double-roll mill	29
Figure 14: Scheme of internal mixer.....	30
Figure 15: Sulfur vulcanization.....	31
Figure 16: Vulcanization curve [18]	32
Figure 17: Wohler curve (S/N curve).....	34
Figure 18: The crack propagation energy G is a product of a term G_0 derived from the bond breaking at the crack tip, and a term $f(v, T)$ derived from the bulk viscoelastic energy dissipation in front of the tip. [7]	36
Figure 19: Scheme of Pure-shear specimen	37
Figure 20: Dependence of crack grow rate on tearing energy [21].....	39
Figure 21: Parameter P [32]	40
Figure 22: Intrinsic strength analyzer (ISA™) (left), Detail on the cutted test specimen during operating (right). [37]	47
Figure 23: Measurement principle, where: A – actuator of the axis Y; B – actuator of the axis X; C – loading cell of the axis X; D – loading cell of the axis Y; E – razor blade; F – test specimen; G – upper clamping system of test specimen; H – bottom clamping system of test specimen, I – razor blade tip [37]	47

Figure 24: Sample with a fixing shoulder of the following dimensions: $L_0 = 4$ mm, $W_p = 40$ mm, $B =$ from 0,5 up to 2 mm, $R = 3$ mm. [35]	50
Figure 25: Tear and Fatigue Analyzer	51
Figure 26: Simple plane sample of the following dimensions: $E = 24$ mm, $W_p = 40$ mm, $B = 1$ mm.	52
Figure 27: Scheme of mechanical loading	52
Figure 28: Tensile test - modulus	54
Figure 29: Dependence of cutting energy vs tearing energy for A5, A6	55
Figure 30: Dependence of cutting energy vs tearing energy for B5, B6	55
Figure 31: Dependence of Crack growth rate vs. Tearing energy for A5	57
Figure 32: Dependence of Crack growth rate vs. Tearing energy for A6	57
Figure 33: Dependence of Crack growth rate vs. Tearing energy for B5	58
Figure 34: Dependence of Crack growth rate vs. Tearing energy for B6	59
Figure 35: Dependence of Crack growth rate vs. Tearing energy for all material	60

LIST OF TABLES

Tab. 1: Recipe of compounds in phr	43
Tab. 2: First step of mixing	44
Tab. 3: Second step of mixing.....	44
Tab. 4: Rheological parameters of prepared rubber compounds for 175 °C	45
Tab. 5: Measurement parameters	49
Tab. 6: Boundary conditions	52
Tab. 7: Results of Hardness test.....	53
Tab. 8: Results of tensile test	53
Tab. 9: Average values of crack growth rates	61